

Operation Manual

INKJET PRINTER

CJV200-75

CJV200-130

CJV200-160

Cartridge-ink model

Operation Manual

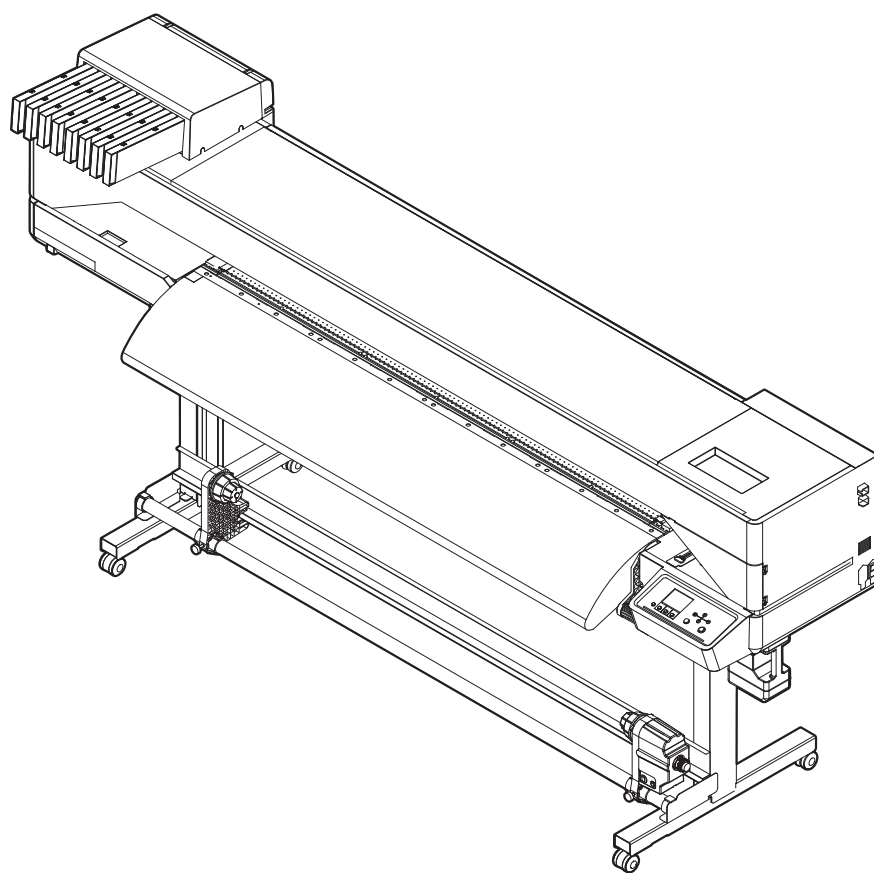

You can also download the latest manual from official website.

MIMAKI ENGINEERING CO., LTD.

<https://mimaki.com/>

D203836-10
Original instructions

TABLE OF CONTENTS

Introduction	6
To Ensure Safe Use	8
Symbol Marks	8
Usage Precautions	9
Notes on Handling Ink or any Other Liquid Used with the Machine	13
Ink Specifications	14
Restrictions Concerning the Expiration Date of Ink Used in the Machine	14
Installation Precautions.....	15
Installation Space	16
When Relocating This Machine	16
Safety Interlocks	17
Warning Label.....	18

Chapter 1 Before Use

1.1 Part Names and Functions	22
Front	22
Rear and Right Side View.....	24
Carriage	25
Station.....	25
Platen.....	25
Pinch Rollers and Grit Rollers.....	26
Media Sensor.....	26
Power Supply Switch	27
Operating Panel.....	28
1.2 Connecting the Power Cable	31
Turning On the Power.....	31
Turning Off the Power.....	32
1.3 Connecting a PC to the Product	33
Using a LAN Cable	33
Using a USB Cable.....	34
1.4 System Configuration	35
Installing the Mimaki Driver.....	36
Installing RIP Software	36
Obtaining Color Profiles	36
Setting Up RIP Software.....	36
1.5 Ink Replacement Method.....	38
When Ink Near End is Displayed	38
When Ink End is Displayed.....	38
Replacing Ink	39

Chapter 2 Printing

2.1 Print Process	42
2.2 Adjusting Print Head Height.....	45

2.3 Adjust the Pinch Roller Positions.....	46
1,600 mm Size.....	47
1,300 mm Size.....	48
750 mm Size.....	49
2.4 Loading the Media	50
Media	50
Take-up unit.....	51
Feeding unit.....	53
Loading the Roll Media	55
Setting Leaf Media.....	60
Registering the Media.....	63
2.5 Setting the Pressure and Number of Pinch Rollers to Use.....	65
2.6 Setting the Heater Temperature	66
2.7 Test Printing.....	67
Changing the Layout Direction for Test Printing	67
Ejection Failures	68
2.8 Head Cleaning	69
2.9 Auto Correction.....	70
2.10 Feed Correction	71
Feed Correction Procedure	71
2.11 Correcting the Drop Position.....	73
Drop Position Correction Procedure	73
2.12 Preparing RIP data	75
2.13 Printing.....	77
Changing the origin.....	77
Starting Printing	78
Stopping Printing (Data Clear).....	79
2.14 Cutting the media.....	80

Chapter 3 Cutting

3.1 Cutting Process	82
3.2 Installing Cutting Tools	84
Using the Cutter.....	84
Using a Pen	88
3.3 Setting the Cutting Conditions	92
3.4 Test Cutting	93
3.5 Cutting the Cutting Data	94
Changing the origin.....	94
Starting Cutting	94
Stopping Cutting (Data Clear).....	95
Retracting the Cutter Unit	95

Chapter 4 Cutting Data with Register Marks

4.1 Process for Cutting Data with Register Marks	98
--	----

4.2 Creating Register Marks	100
Register Marks.....	100
Register Mark Size	101
Spacing Between Register Marks.....	102
Reading Range of Register Marks.....	103
No-Plotting Areas Around Register Marks.....	104
Combined Operations of Printing and Cutting	105
4.3 Setting Mark Detection Conditions	106
4.4 Detecting the Position of the Register Mark Origin.....	107
4.5 ID Cut Process.....	108

Chapter 5 Setup

5.1 Media Setting Menu.....	110
5.2 Maintenance Menu	113
Registering Nozzle Recovery Manually	115
Nozzle Check (Option).....	116
5.3 Function Setting Menu.....	117
5.4 Environment Setting Menu	119
5.5 Machine Status Menu	121
5.6 Cutting Menu	122
Copying the Last Data	124
Preventing Uncut Media	125

Chapter 6 Maintenance

6.1 Maintenance Precautions	128
6.2 Maintenance Methods	129
Maintenance Items and Timing.....	129
Ink Maintenance	130
Cap Rubber Cleaning	130
Carriage Underside Cleaning	131
Wiper Cleaning	132
Cleaning the NCU (Option).....	134
DAS (Automatic Correction Function) Sensor Cleaning	135
Ink Discharge Channel Cleaning	136
Media Sensor Cleaning	137
Media Cutter Cleaning	137
Media Holder Cleaning	139
Jam Sensor Detecting Plate Cleaning	139
Platen Cleaning	140
Cover (Exterior) Cleaning	140
When this Printer is Left Unused for a Long Time	140

6.3 Replacement of Consumable Item	143
Consumable Item Replacement Timing.....	143
Wiper Replacement	144
Cap Replacement	145
Replacing the Absorber Around the Station	146
Pinch Roller Replacement	148
Media Holder Replacement	148
Media Cutter Replacement	150
Waste Ink Tank Replacement.....	151
Cutter for Cutting Machine	154
Pen Line Replacement	154

Chapter 7 Troubleshooting

7.1 Troubleshooting	158
The power does not turn on.....	158
Printing is not possible.....	158
The media jams or the media is dirty.....	158
Image defects occur.	159
The heater temperature does not rise to the specified value.....	161
The ink has leaked out.....	162
Cutting Related	162
7.2 Problems Causing Messages to Appear	167
Warning Messages	167
Ink error	168
Error Message	169
SYSTEM HALT	176

Chapter 8 Appendix

8.1 Specifications.....	178
-------------------------	-----

Introduction

Thank you for purchasing the Inkjet printer CJV200 series.

Read this operating manual ("this document" hereinafter) thoroughly and make sure you understand its contents to ensure safe and correct use of the product.

Please note that the illustrations contained in this manual are intended to show functions, procedures, or operations and may sometimes differ slightly from the actual machine.

Adobe, the Adobe logo, Acrobat, Illustrator, Photoshop, and PostScript are the trademarks or registered trademarks of Adobe Incorporated in the United States and other countries.

RasterLink is a trademark or a registered trademark of Mimaki Engineering Co. Ltd. in Japan and other countries.

Other company and product names mentioned herein are the trademarks or registered trademarks of the respective companies in Japan and in other countries.

Unauthorized reproduction of any portion of this document is strictly prohibited.

© 2024 MIMAKI ENGINEERING Co., Ltd.

● DISCLAIMERS

- MIMAKI ENGINEERING REJECTS ALL LIABILITY FOR DAMAGE ARISING DIRECTLY OR INDIRECTLY FROM THE USE OF THE CJV200 series ("THIS MACHINE" HEREINAFTER), WHETHER OR NOT THE PRODUCT IS FAULTY.
- MIMAKI ENGINEERING REJECTS ALL LIABILITY FOR DAMAGE, DIRECT OR INDIRECT, TO MATERIALS CREATED WHILE USING THIS MACHINE.
- USING THIS MACHINE IN CONJUNCTION WITH DEVICES OTHER THAN THOSE RECOMMENDED BY MIMAKI ENGINEERING MAY RESULT IN FIRE OR ACCIDENTS. SUCH INCIDENTS ARE NOT COVERED BY THE PRODUCT WARRANTY. MIMAKI ENGINEERING REJECTS ALL LIABILITY FOR DAMAGE, DIRECT OR INDIRECT, ARISING FROM SUCH INCIDENTS.
- USE ONLY GENUINE MIMAKI ENGINEERING INK AND MAINTENANCE LIQUID. USE OF OTHER PRODUCTS MAY RESULT IN FAILURES OR REDUCE PRINT QUALITY. SUCH INCIDENTS ARE NOT COVERED BY THE PRODUCT WARRANTY. MIMAKI ENGINEERING REJECTS ALL LIABILITY FOR DAMAGE, DIRECT OR INDIRECT, ARISING FROM SUCH INCIDENTS.
- DO NOT ATTEMPT TO REFILL THE INK CARTRIDGES WITH UNAUTHORIZED INK. SUCH INCIDENTS ARE NOT COVERED BY THE PRODUCT WARRANTY. MIMAKI ENGINEERING REJECTS ALL LIABILITY FOR DAMAGE, DIRECT OR INDIRECT, ARISING FROM SUCH INCIDENTS.

● TV and radio interference



- The machine emits high-frequency electromagnetic radiation while operating. Under certain circumstances, this may result in TV or radio interference. We make no guarantee that this machine will not affect special radio or TV equipment.
-

If radio or TV interference occurs, check the radio or TV reception after turning off the machine. If the interference disappears when the power is turned off, the machine is likely to be the cause of the interference.

Try any of the following solutions or combinations of these solutions:

- Change the orientation of the TV or radio antenna to find a position where interference does not occur.
- Move the TV or radio away from this machine.
- Plug the TV or radio into a power outlet on a power circuit other than the power circuit to which this machine is connected.

● FCC (Federal Communications Commission) regulations

The machine has been tested and certified to comply with restrictions applying to Class A digital devices under Part 15 of the FCC regulations. These restrictions are designed to provide suitable protection from harmful interference when the printer is used in commercial environments.

This product may generate, use, or emit radio frequency energy and may cause harmful interference with radio communications if not installed or used in accordance with the operating manual.

Use of this product in residential areas may cause harmful interference. If so, the user is responsible for rectifying such interference.











- Use only the cables recommended by Mimaki Engineering when connecting to the machine. Use of other cables may cause the product to exceed the restrictions stipulated by FCC regulations. To maintain compliance with FCC regulations, use the cables recommended by Mimaki Engineering.
-

To Ensure Safe Use

Symbol Marks

This document uses symbol marks to explain precautions when operating the machine. Make sure you fully understand the meaning of each mark to ensure safe and correct use of the machine.

Explanation		
	Warning	Indicates a potential hazard that may result in death or serious injury if handled improperly or if instructions are disregarded.
	Caution	Indicates a potential hazard that may result in minor or moderate injury if handled improperly or if instructions are disregarded.
	Notice	Indicates a potential hazard that may result in property damage if handled improperly or if instructions are disregarded.
	Warning sign	Indicates something that requires attention. Warning specifics are drawn inside the symbol.
	Mandatory action sign	Indicates an action that must be carried out. The specifics of the mandatory action are drawn inside the symbol.
	Prohibition sign	Indicates a prohibited action. The specifics of the prohibited action are drawn inside the symbol.
	Important	Indicates important information related to use of this machine.
	Tip	Indicates useful reference information.
	Reference information	Indicates the corresponding page for related information.

Usage Precautions

● In the event of abnormal conditions

WARNING



- In the event of abnormal conditions such as smoke or unusual odor, turn off the main power immediately and unplug the power cable. Continuing to use the machine under these conditions may result in failure, electric shock, or fire. Once you have confirmed that smoke is no longer being emitted, contact your local dealer or our service office. Never attempt to repair the machine yourself, which is hazardous.

CAUTION



- Immediately wipe off any ink, maintenance liquid, waste ink, or other liquid used with the product that comes into contact with your skin. Then wash using soap, and rinse with plenty of water. Failure to wash off ink may result in skin inflammation. If your skin becomes irritated or painful, seek medical attention immediately.
- If ink, maintenance liquid, waste ink, or any other liquid used in the product comes into contact with your eyes, rinse immediately with plenty of clean water. Rinse for at least 15 minutes. If you wear contact lenses and they can be easily removed, remove after rinsing for at least 15 minutes with clean water. Be sure to also rinse the undersides of your eyelids. Failure to rinse off ink may result in blindness or impaired vision. If your eyes become irritated or painful, seek medical attention immediately.
- If ink, maintenance liquid, waste ink, or any other liquid used in the product enters your mouth or is swallowed, gargle with water immediately. Do not induce vomiting. Seek medical attention promptly. Inducing vomiting may cause liquid to enter the airway.
- If a large amount of vapor is inhaled, move to a well-ventilated area, keep warm, and rest in a posture that allows easy breathing. If the condition does not improve, seek medical attention promptly.

NOTICE



- If an ink leak occurs, turn off the main power immediately and unplug the power cable. Then, contact your local dealer or our service office.

● Power supply precautions

⚠ WARNING



- Use the power cable provided. Otherwise there is a risk of failure, electric shock, or fire. The power cable provided is exclusive for the machine, and must not be used for other electrical equipment.
- Always hold the plug when removing the power cable. Pulling out the power cable may damage the cable, leading to failure, electric shock, or fire.
- Do not use the machine with dust accumulated on the power plug. Otherwise there is a risk of failure, electric shock, or fire.
- Take care to prevent metals from touching the power plug blades. Otherwise there is a risk of failure, electric shock, or fire.
- Do not damage or modify the power cable. Do not place heavy objects on, heat or stretch it. Doing so may damage the cable, leading to electric shock or fire.
- Do not use extension cords or power strips. Otherwise there is a risk of failure, electric shock, or fire.
- Do not use the power cable if it is damaged or broken or if the core wire is exposed. Otherwise there is a risk of failure, electric shock, or fire.
- Do not handle the power plug with wet hands. Disregarding this precaution may result in electric shock.



- Plug the power cable plug into a grounded power outlet. Otherwise there is a risk of failure, electric shock, or fire.
- When installing electrical outlets, perform grounding work to prevent electric shock. All electrical work (Class C grounding work; formerly Type 3 grounding work) must be handled by a licensed electrician.

NOTICE



- Do not turn off the main power supply. Turning off the main power supply will disable the automatic maintenance function (including nozzle clogging prevention function and ink discharge channel cleaning function). This increases the risk of ejection failures (such as nozzle clogging or deflection).

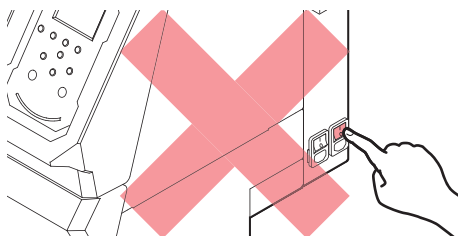

- Use the machine with a power supply that meets specifications.
- Be sure to plug the power cable into a power outlet close to the machine. Insert the power plug blade securely.
- When connecting the power cable, check the input voltage of the power outlet and the capacity of the breaker. Also, connect each cable to a separate power source with an independent breaker. Connecting to power outlets linked with the same breaker will cause the breaker to trip.

● Caution regarding moving parts

⚠ CAUTION



- Keep parts of the body such as the face and hands away from moving parts. Also keep clothing (e.g., loose clothing and accessories) that may impede work away from the machine. Failure to do so may result in injury.



- Long hair should be tied back. Failure to do so may result in injury.

● Do not disassemble or repair

⚠ WARNING



- Do not attempt to disassemble or repair this machine. Otherwise there is a risk of failure, electric shock, or fire.

● Handling the cutter

⚠ CAUTION



- Avoid touching the cutter blade. Failure to do so may result in injury.
- Do not shake or swing the cutter holder. Doing so may cause the blade to come off.

● Heater

⚠ CAUTION



- The heater becomes extremely hot. Do not touch with bare hands.

NOTICE

● Other usage precautions

⚠ WARNING



- Keep children away from the machine.

NOTICE



- Do not pull the media when the clamp lever is lowered (the media is clamped). Doing so may damage the machine.



- The underside of the media may be soiled depending on how the printed media has been stored (due to weight when laying printed media rolls horizontally, for example) and the media type. Perform a test beforehand to check that the media does not transfer ink to the underside of the adjacent media.

● Disposing of the product

⚠ CAUTION



- Please contact your local retailer or service agent.
 - When disposing of the product yourself, contact an industrial waste disposal operator or dispose of the product in accordance with local laws and regulations.
-

Notes on Handling Ink or any Other Liquid Used with the Machine

Precautions regarding ink, maintenance liquid, or other liquids used with this machine are included with the containers. Thoroughly read them and make sure you understand the contents.



- Be sure to read the safety data sheet (SDS) before use. <https://mimaki.com/supply/sds/>

CAUTION



- Pay close attention to ventilation and be sure to wear safety glasses, gloves, and a mask when handling ink, maintenance liquid, waste ink, or other solutions used with the machine. Leaking ink may adhere to the skin or get into the eyes or mouth.



- Do not subject cases containing ink to strong shock or violent shaking. Do not attempt to refill the ink. Leaking ink may adhere to the skin or get into your eyes or mouth.



- Do not disassemble cases containing ink. Leaking ink may adhere to the skin or get into your eyes or mouth.



- Do not store ink, maintenance liquid, or other liquids used with the machine in locations where children may enter.



- When disposing of ink, maintenance liquid or other liquid used with the product, or containers or non-woven fabric contaminated with ink or other liquid, contact an industrial waste disposal operator or dispose of the product in accordance with the local laws and regulations.

NOTICE



- Do not store ink, maintenance liquid, or other liquids used with the machine in locations exposed to direct sunlight.
- Do not store ink, maintenance liquid, or other liquids used with the machine in environments where cutting fluid or other volatile substances (such as amines or modified amine alcohol) are present in significant quantities. Storage in such places increases the risk of failure or ejection failures (e.g., nozzle clogging or deflection).
- Do not use ink, maintenance liquid, or other liquids used with this machine with other printers. Doing so may cause failure.



- Be sure to store them in a low place no higher than 1 m above the floor. Otherwise there is a risk of scattering if the containers fall.
- Store in tightly sealed containers.
- Store in a cool, dark place.
 - (1) Store ink in a place where ink does not freeze. Using defrosted ink may deteriorate ink constituents and reduce print quality.
 - (2) When ink is moved from a cold place to a warm place, leave it in the environment where the machine is installed for at least three hours before using it.
 - (3) Open the container just before installing it, and use it up as quickly as possible. If it is opened and left for an extended period of time, print quality may be reduced.



- Do not touch the metal parts of the ink IC chip. Static electricity may damage the ink IC chip, and dirt or damage may cause the ink IC chip read error.



- Printing is disabled if a different ink IC chip is used.

Ink Specifications

Item		Details
Type		Special solvent ink (Mimaki Engineering product)
Color ^{*1}		Cyan (C) Magenta (M) Yellow (Y) Black (K) Light cyan (Lc) Light magenta (Lm) Light black (Lk) Orange (Or)
Form		Aluminum pack
Ink capacity ^{*1}		440 ml
Expiration date		As indicated on the ink pack. However, after opening, it should be consumed within three months, even if before the expiration date.
Storage temperature	When stored	10 to 35 °C (daily mean temperature) <ul style="list-style-type: none"> • However, not more than 1 month at 30 °C • Ink quality may deteriorate if stored outside these conditions.
	During transportation	1 to 40 °C <ul style="list-style-type: none"> • However, not more than 120 hours at 60 °C, and not more than 1 month at 40 °C • Where possible, avoid storing in cold locations below 0 °C and hot locations above 40 °C. • Ink quality may deteriorate if stored outside these conditions.

*1. Depending on ink type

Restrictions Concerning the Expiration Date of Ink Used in the Machine

Example: When the expiration date is April 20xx

- May 20xx: Replace with new ink or use up as quickly as possible. Printing is possible.
- June 20xx: Replace with new ink or use up as quickly as possible. Printing is possible.
- July 20xx: Printing is not possible.



- The message appears on the display.



- The ink expiration date is indicated on the ink container. Expired ink may cause ejection failures or alter the color tone. Printing is possible even if the ink has passed its expiration date. Nevertheless, we recommend replacing with new ink or using up as quickly as possible.

Installation Precautions

WARNING



- Do not install the machine in a place close to fire. Doing so may result in inflammation of solvent ink.
- Do not place flower vases, pots, cups, containers containing cosmetics, chemicals or water, or small metal items on or close to the machine. If they enter the machine, there is a risk of failure, electric shock, or fire.



- Do not install this machine in humid locations or locations where it may be exposed to splashing water. Otherwise there is a risk of failure, electric shock, or fire.



- Do not install the machine in a place where children may enter.

CAUTION



- A ventilation system must be provided if this machine is installed in a poorly ventilated area or sealed room.
- Be sure to observe the following points when installing an extractor outlet:
 - (1) The extractor outlet must be installed in accordance with applicable local EHS (environmental, health, and safety) guidelines.
 - (2) If the extractor outlet is fitted with a shutoff valve, the valve must be open when this machine is in use.

NOTICE



- Do not install this machine in locations where dust or powder is present. Failure or printing defects may result (e.g., nozzle clogging, deflection) if dust gets inside this machine.
- Do not install this machine in locations exposed to drafts (e.g., from air conditioning). Disregarding this precaution may result in dust or powder getting inside this machine.
- Do not install this machine in unstable locations or locations subject to vibration. This will increase the risk of failure or printing defects (e.g., nozzle clogging, deflection).
- Do not install this machine in locations exposed to direct sunlight.
- Do not install this machine in locations subject to sudden temperature changes. This will increase the risk of failure or printing defects (e.g., nozzle clogging, deflection).
- Do not install this machine in locations exposed to excessive noise from large machinery.
- Do not install this machine in locations where photographic fixing agents generate vapor or acid gas (e.g., acetic acid, hydrochloric acid) or locations filled with metal working fluids or highly volatile substances (e.g., amines, amine-modified alcohols). Malfunctions or printing defects may result (e.g., nozzle clogging, deflection) as print head ink is more likely to harden under such environments.



- Operating environment: 20 to 30 °C (68 to 86 °F), 35 to 65 %RH (no condensation)
- Temperature range in which accuracy is guaranteed: 20 to 25 °C (68 to 77 °F)

Installation Space

Provide the following space around the machine to allow safe and proper replacement of ink and media:

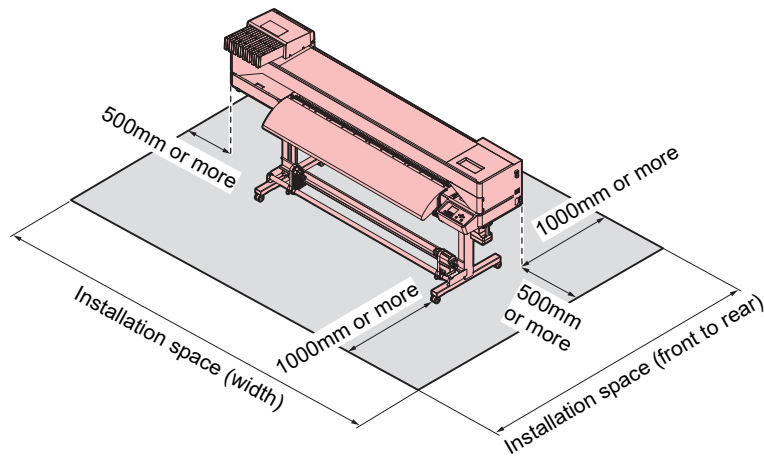

● CJV200 series

Size	160	130	75
Width ^{*1}	At least 3,770 mm (2,770 mm)	At least 3,520 mm (2,520 mm)	At least 2,960 mm (1,960 mm)
Depth ^{*1}	At least 2,748 mm (748 mm)		
Height ^{*1}	(1,370 mm)		
Weight	(140 kg)	(130 kg)	(105 kg)

*1. The figures in parentheses indicate machine dimensions.

When Relocating This Machine

Contact your local dealer or our service office. Attempting to handle relocation yourself may result in failure or damage.

Safety Interlocks

The machine is equipped with interlocks to ensure safety during use.

Printing will abort if you open the covers while printing is underway. The RIP data will need to be resent.

- Safety interlock locations

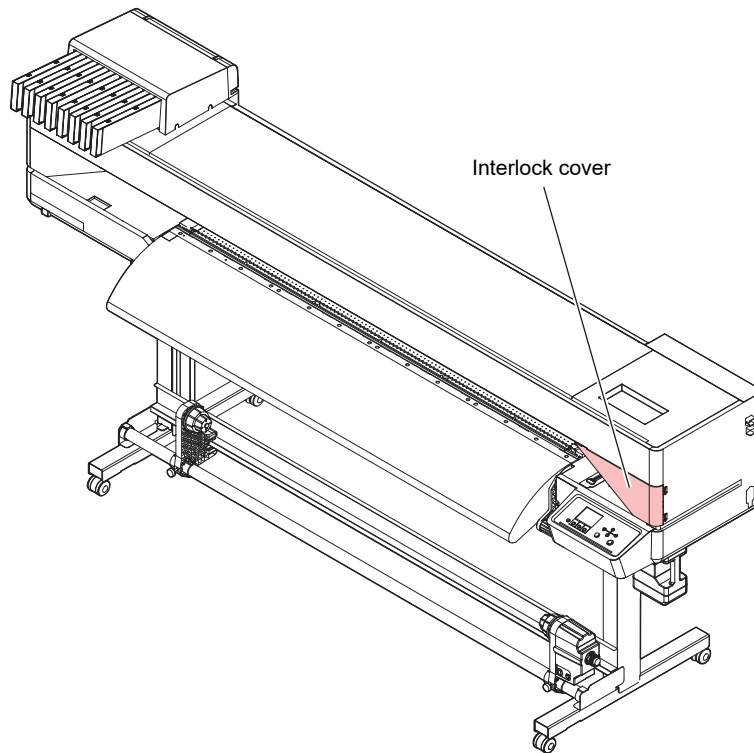







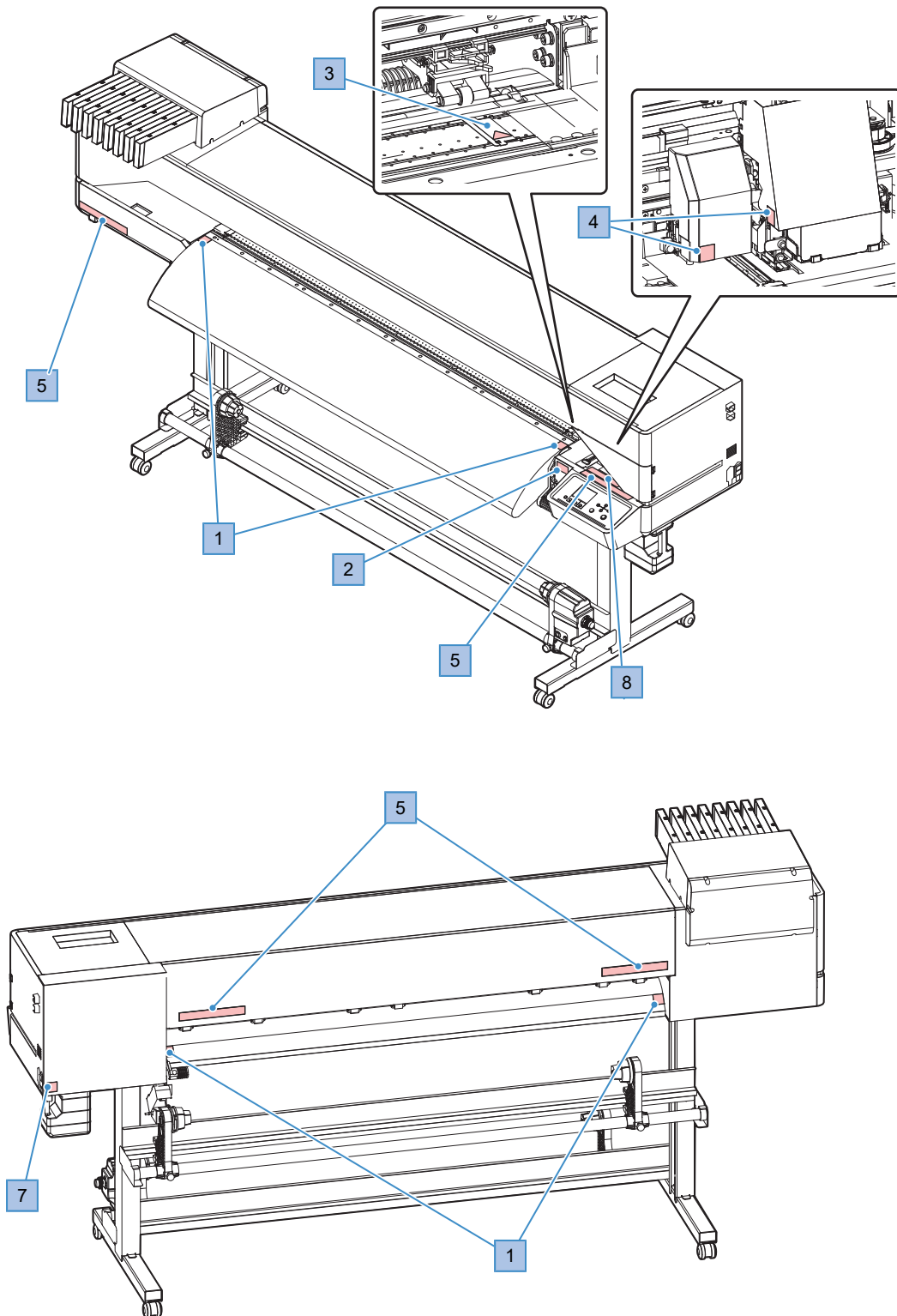

Warning Label

Make sure you fully understand the details indicated on the various warning labels.

If any of the warning labels becomes dirty and illegible or peel off, contact your local dealer or our service office to request new warning labels.



No.	Order code	Label	Details
1	M903239		Indicates hot parts.
2	M903330		Wear safety glasses and gloves while working.
3	M919855		Indicates hot parts.
4	M903405		Beware of the cutter.
5	M905811		Indicates dangerous moving parts.
6	M906031	 <p>This unit has two power cords. For removal of all power, disconnects both cords.</p> <p>Cet appareil a deux cordons secteur. Pour le mettre hors tension, débranchez ces deux cordons secteur.</p> <p>本機は、2本の電源ケーブルがある。電源をオフする場合、2本とも抜くこと。</p>	Describes the power cable.
7	M907935		Indicates dangerous live parts.
8	M905935	 <p>Do not move 2 levers of the pinch roller with hands. Or malfunctions may occur.</p> <p>ピンチローラーの2つのレバーは、手動で動かさないこと。誤作動の原因になる。</p> <p>Ne pas déplacer les deux leviers du galet presseurs manuellement. Cela peut provoquer un dysfonctionnement de l'appareil.</p>	Avoid touching the pinch roller lever.

Chapter 1 Before Use



This chapter

This chapter describes information essential before use, such as part names.

Part Names and Functions	22	Connecting a PC to the Product.....	33
Front.....	22	Using a LAN Cable	33
Rear and Right Side View.....	24	Using a USB Cable	34
Carriage	25	System Configuration	35
Station.....	25	Installing the Mimaki Driver.....	36
Platen.....	25	Installing RIP Software.....	36
Pinch Rollers and Grit Rollers.....	26	Obtaining Color Profiles	36
Media Sensor	26	Setting Up RIP Software	36
Power Supply Switch	27	Ink Replacement Method	38
Operating Panel	28	When Ink Near End is Displayed	38
Connecting the Power Cable.....	31	When Ink End is Displayed	38
Turning On the Power	31	Replacing Ink	39
Turning Off the Power	32		

1.1 Part Names and Functions

Front

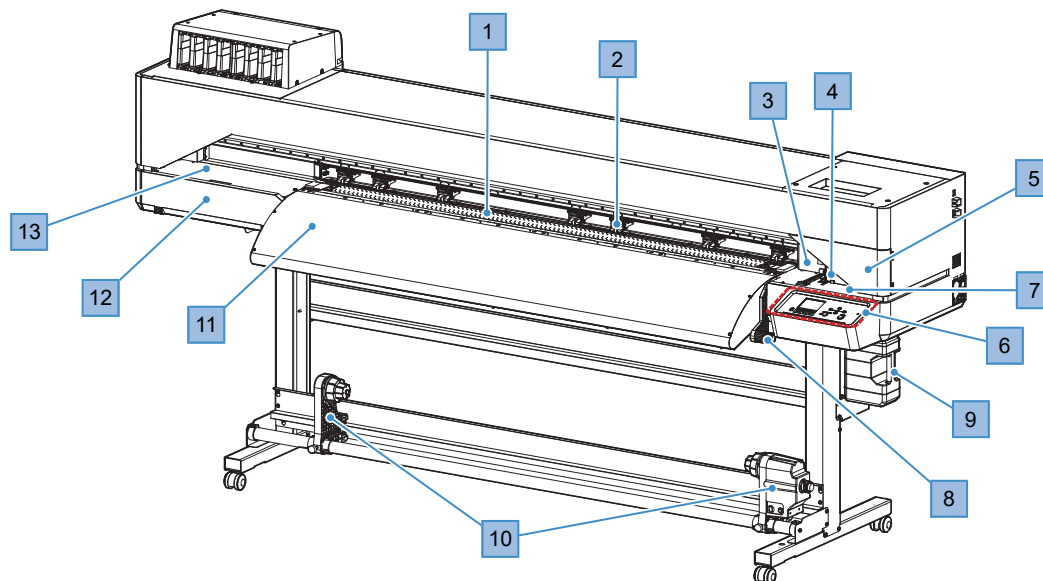

No.	Name	Overview
1	Platen	Print area. "Platen"(P. 25) The platen is fitted with a heater to prevent ink bleeding. Adjust the temperature setting to suit the type of media used. "Setting the Heater Temperature"(P. 66)
2	Pinch roller Grit roller	The pinch rollers and grit rollers are used to grip and feed the media. "Pinch Rollers and Grit Rollers"(P. 26)
3	Cutter unit	Holds a cutter and a pen for cutting. "Cutting"(P. 81) "Cutting Data with Register Marks"(P. 97)
4	Carriage	Consists of a print head, the jam sensor, and the media cutter. "Carriage"(P. 25)
5	Maintenance cover (right side)	Open the cover to perform maintenance on the station, etc. Printing and automatic maintenance are not possible while the covers are open.
6	Operating Panel	Includes operating keys and displays indicating various settings and other items. "Operating Panel"(P. 28)
7	Station	Includes caps for protecting the print head, wipers, and an NCU (option) for monitoring print head nozzle conditions. "Station"(P. 25)
8	Clamp lever	Lowering the clamp lever secures the media. Raising the clamp lever releases the media. Linked to the clamp lever at the rear.
9	Waste Ink Tank	Contains the container for waste ink. "Waste Ink Tank Replacement"(P. 151)
10	Take-up unit	Rolls up the printed roll media. "Take-up unit"(P. 51)
11	Post-heater	Allows ink to dry after printing. Adjust the temperature setting to suit the type of media used. "Setting the Heater Temperature"(P. 66)
12	Maintenance cover (left side)	Open the cover to perform maintenance on locations such as the carriage underside. Printing and automatic maintenance are not possible while the covers are open.

No.	Name	Overview
13	Maintenance cover (upper left side)	Open the cover to perform maintenance on locations such as the carriage underside. Printing and automatic maintenance are not possible while the covers are open.

Rear and Right Side View

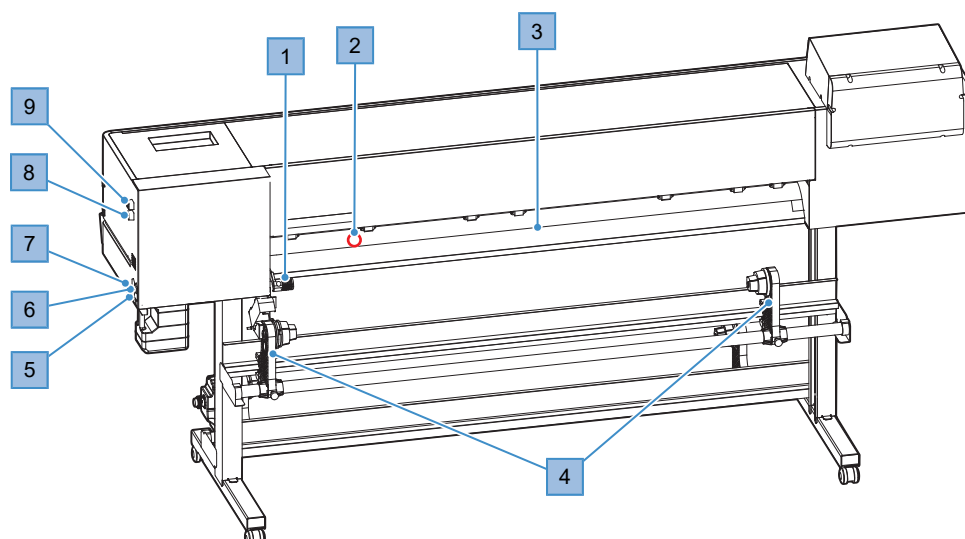

No.	Name	Overview
1	Clamp lever	Linked to the clamp lever at the front.
2	Media Sensor	Detects whether media is present. 📖 "Media Sensor"(P. 26)
3	Preheater	Preheats the media before printing to suppress rapid temperature change. Adjust the temperature setting to suit the type of media used. 📖 "Setting the Heater Temperature"(P. 66)
4	Feeding unit	Compatible with 2-inch and 3-inch paper cores. 📖 "Loading the Roll Media"(P. 55)
5	AC inlet	The inlet at the rear (INLET1) is for the machine and the inlet at the front (INLET2) is for the heater. Use the power cable provided. 📖 "Connecting the Power Cable"(P. 31)
6	Main power switch	The main power supply for the machine. To prevent ejection failures attributable to the print head (e.g., nozzle clogging or deflection), do not turn off the main power supply. 📖 "Power Supply Switch"(P. 27) 📖 "Turning On the Power"(P. 31) 📖 "Turning Off the Power"(P. 32)
7	Heater power supply switch	The power supply switch at the front is for the heater. Setting the Heater Temperature
8	LAN port	Connects to PC via a LAN cable. 📖 "Using a LAN Cable"(P. 33)
9	USB port	Connects to PC via a USB interface cable. 📖 "Using a USB Cable"(P. 34)

Carriage

The carriage includes a print head for ejecting ink, and a jam sensor for stopping the carriage when media clogs. Printing occurs as ink is ejected while traversing left and right.

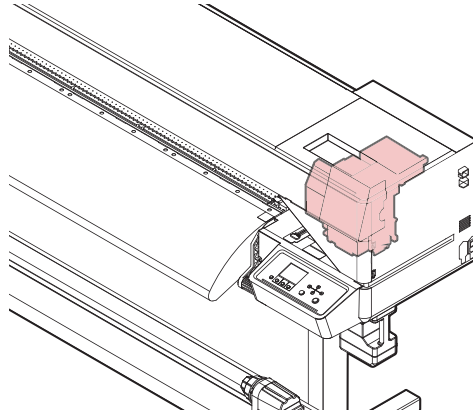

Station

The station includes caps for keeping the print head nozzle surface from drying out, a wiper required for print head maintenance, and an NCU (option) for monitoring print head nozzle conditions.

The NCU (Nozzle Check Unit) automatically checks whether the nozzle is clogged. Setting various functions enables automatic print head cleaning or printing using other nozzles. (NCU is optional.)

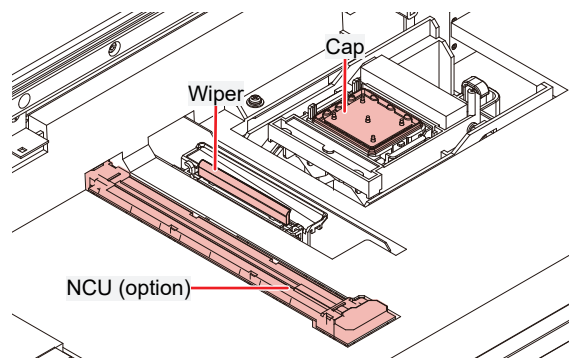

Platen

Print area. The platen secures the media under vacuum pressure. This also features a cutting slot for cutting the media.

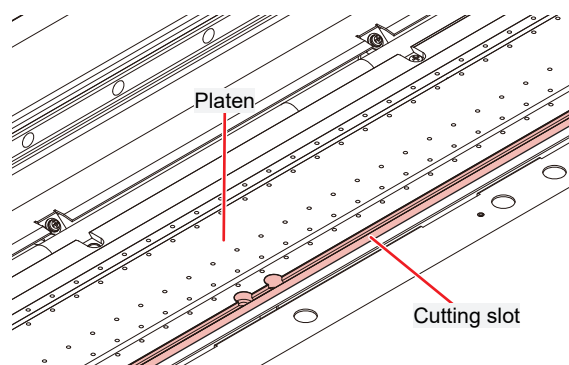

Pinch Rollers and Grit Rollers

The pinch rollers and grit rollers are used to grip and feed the media.

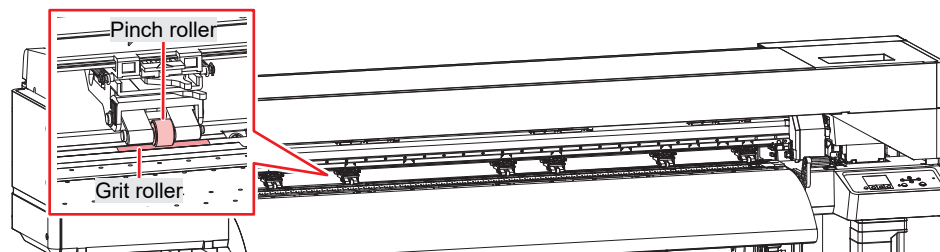

When the machine is not in use, raise the clamp lever to **separate the pinch rollers from the grit rollers**.

- Leaving the pinch rollers lowered may cause them to become deformed and prevent media from being fed correctly.
- Leaving media loaded will subject it to force from the pinch rollers, which may leave pinch roller marks on it.

Media Sensor

The media sensor detects the presence/absence of media. The sensor must be covered by the media to detect the media width.

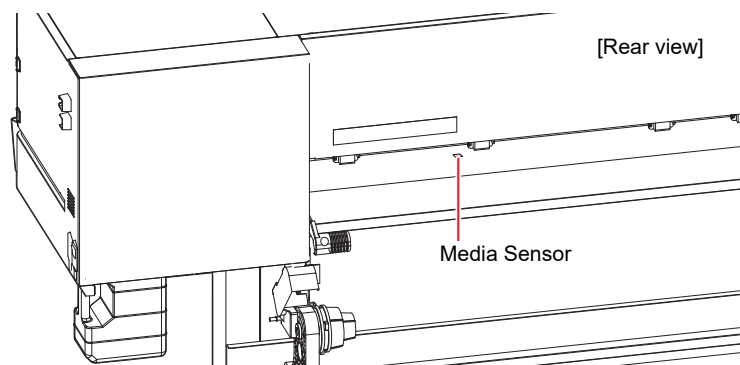

Power Supply Switch

● Main power switch

This is located at the rear on the right-hand side of the product.

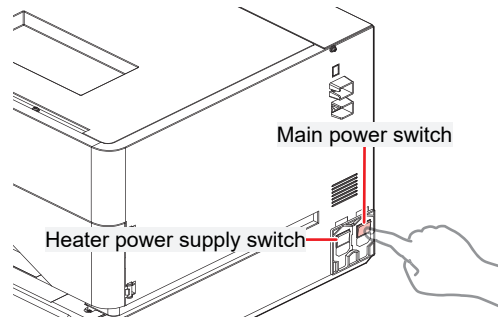

- Do not turn off the main power supply. Turning off the main power supply will disable the automatic maintenance function (including nozzle clogging prevention function and ink discharge channel cleaning function). This increases the risk of ejection failures (such as nozzle clogging or deflection).

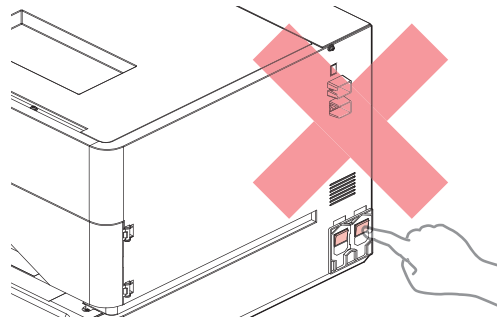

● [END/POWER] key

The [END/POWER] key is the key normally used to turn the power on and off.

To turn off the power, hold down the [END/POWER] key. Press the [ENTER] key once the instructions appear on the display.

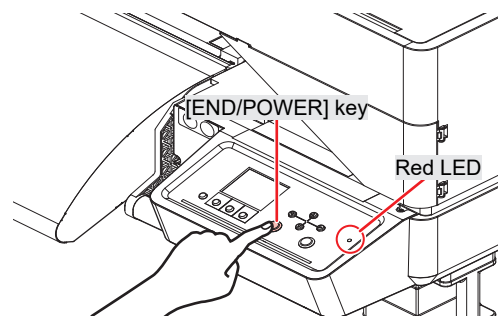

Operating Panel

This is used to control the product and make/change settings.

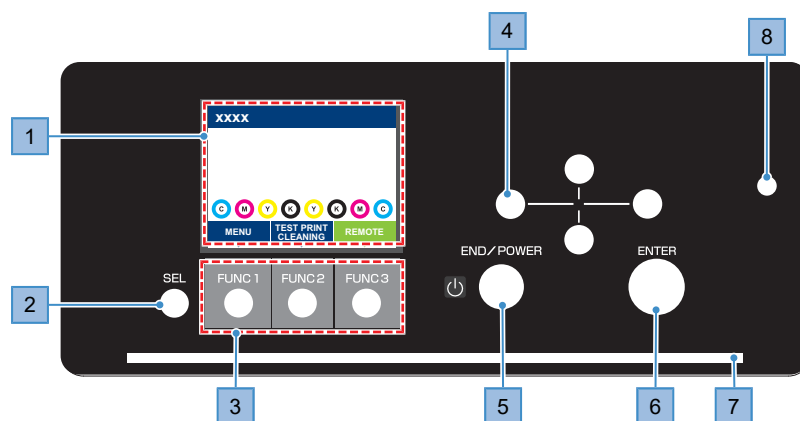

No.	Name	Overview																						
1	Display	"Display" (P. 29)																						
2	[SEL] key	Selects the function for the corresponding [FUNCTION] key.																						
3	[FUNCTION] key	Used for test printing, head cleaning, and editing settings. "[FUNCTION] key" (P. 30)																						
4	[JOG] key 	Used to move the carriage, feed media, and select settings																						
5	[END/POWER] key	Used to cancel the last setting entered, return to the previous level of the setting menu, or to turn power on and off <ul style="list-style-type: none"> • Illuminates in blue when the power is on. "Turning On the Power"(P. 31) • To turn off the power, hold down the key. "Turning Off the Power"(P. 32) 																						
6	[ENTER] key	Used to move to the next level menu and to confirm settings. This can also be used to display product information. "Displaying Machine Information (Local Guidance)" (P. 30)																						
7	Status lamp	This lamp indicates the machine status. <table border="1"> <tbody> <tr> <td>Off</td> <td></td> <td>Indicates LOCAL mode. Used for test printing, maintenance, and settings</td> </tr> <tr> <td rowspan="2">Light blue</td> <td>Illuminated</td> <td>Indicates REMOTE mode. The product is in standby to receive print data.</td> </tr> <tr> <td>Flashing</td> <td>Indicates that printing is in progress. This also flashes to indicate test printing—for example, when printing built-in patterns.</td> </tr> <tr> <td>Blue</td> <td>Illuminated</td> <td>Indicates that data remains to be printed. Switch to REMOTE mode and start printing</td> </tr> <tr> <td>Green</td> <td>Flashing</td> <td>Indicates that automatic maintenance is underway. Some functions will be limited until maintenance has ended.</td> </tr> <tr> <td>Yellow</td> <td>Flashing</td> <td>Ink Near End status (very little ink remains). "When Ink Near End is Displayed"(P. 38)</td> </tr> <tr> <td rowspan="2">Red</td> <td>Flashing</td> <td>An error has occurred. Refer to the error code list and take appropriate action. "Error Message"(P. 169)</td> </tr> <tr> <td>Illuminated</td> <td>A system error (SYSTEM HALT) has occurred. Contact our service office. "SYSTEM HALT"(P. 176)</td> </tr> </tbody> </table>	Off		Indicates LOCAL mode. Used for test printing, maintenance, and settings	Light blue	Illuminated	Indicates REMOTE mode. The product is in standby to receive print data.	Flashing	Indicates that printing is in progress. This also flashes to indicate test printing—for example, when printing built-in patterns.	Blue	Illuminated	Indicates that data remains to be printed. Switch to REMOTE mode and start printing	Green	Flashing	Indicates that automatic maintenance is underway. Some functions will be limited until maintenance has ended.	Yellow	Flashing	Ink Near End status (very little ink remains). "When Ink Near End is Displayed" (P. 38)	Red	Flashing	An error has occurred. Refer to the error code list and take appropriate action. "Error Message" (P. 169)	Illuminated	A system error (SYSTEM HALT) has occurred. Contact our service office. "SYSTEM HALT" (P. 176)
Off		Indicates LOCAL mode. Used for test printing, maintenance, and settings																						
Light blue	Illuminated	Indicates REMOTE mode. The product is in standby to receive print data.																						
	Flashing	Indicates that printing is in progress. This also flashes to indicate test printing—for example, when printing built-in patterns.																						
Blue	Illuminated	Indicates that data remains to be printed. Switch to REMOTE mode and start printing																						
Green	Flashing	Indicates that automatic maintenance is underway. Some functions will be limited until maintenance has ended.																						
Yellow	Flashing	Ink Near End status (very little ink remains). "When Ink Near End is Displayed" (P. 38)																						
Red	Flashing	An error has occurred. Refer to the error code list and take appropriate action. "Error Message" (P. 169)																						
	Illuminated	A system error (SYSTEM HALT) has occurred. Contact our service office. "SYSTEM HALT" (P. 176)																						
8	LED	To turn on power, press the [END/POWER] key until the red LED illuminates, then release the key.																						

Display

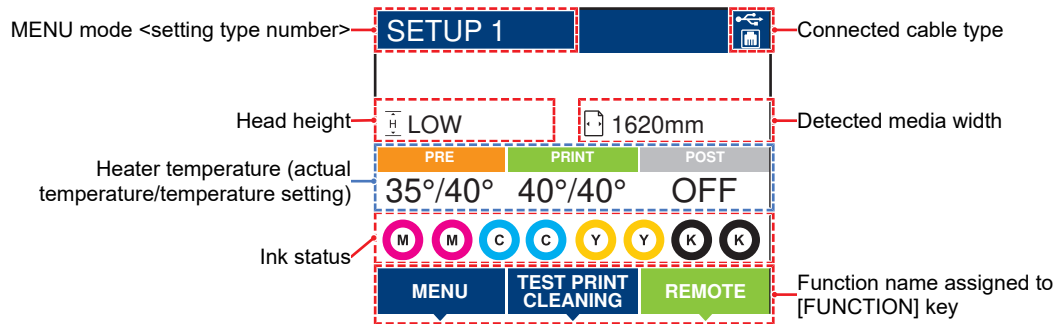

● Heater temperature

The heater status is indicated by different colors.

- Orange: Adjusting to temperature setting.
- Green: At temperature setting.
- Gray: Heater is turned off.

MENU mode

Four menu modes are available.

Name	Overview
LOCAL mode	Used for test printing, maintenance, and settings
REMOTE mode	Prints the print data received from a PC.
MENU mode	Press the [MENU] on the LOCAL mode screen to switch to MENU mode. This is used to set various functions.
NOT-READY mode	Status before media is detected



















Ink status

The ink pack status such as remaining ink levels and ink errors are indicated by icons.

Icon	Overview
	Displays remaining ink levels using a 9-stage icon.
	Full
	1/8 used
	1/4 used
	3/8 used
	1/2 used
	5/8 used
	3/4 used
	7/8 used
	Very little ink remains. Prepare fresh ink.
	Printing is not possible. Displayed when ink is depleted or an ink error has occurred. Ink error

[FUNCTION] key

This section describes the functions and roles assigned to the [FUNCTION] key.

Icon	Overview
	Displays the various menu screens.  "Setup"(P. 109)
	Displays maintenance functions such as test printing and cleaning.
	Switches from LOCAL mode to REMOTE mode.
	Displays adjustment functions such as feed adjustment and drop position adjustment.
	Displays the Heater Temperature Setup screen.
	Clears received data.
	Used to switch from REMOTE mode to LOCAL mode
	Used to cut media
	Used to move to the previous menu screen
	Used to move to the next menu screen
	Used to close the confirmation screen in response to prompts or other messages
	Used to disable functions
	Indicates that the function is assigned. Displays settings and functions.
	Used to enable or disable multiple items
	Displays the cutting condition input screen.
	Displays the test cutting and other cutting related function screens.
	Displays the pinch roller setting screen.

Displaying Machine Information (Local Guidance)

Press the [ENTER] key on the LOCAL mode screen to display the following information.

- Ink information: Displays ink type, remaining ink levels, and ink errors.
- Information: Displays information such as media width, head height, product serial number, firmware version, command version, and LAN connection status.
- Nozzle check: Displays the number of nozzles detected as clogged in the nozzle check.

1.2 Connecting the Power Cable

- 1** Check to confirm that the main power supply is turned off.
- 2** Connect the cable band to the machine.
- 3** Connect the power cable to the inlet of the machine.
- 4** Secure the power cable to the cable band.
 - Pass the power cable through the clamp and clamp until it clicks into place.

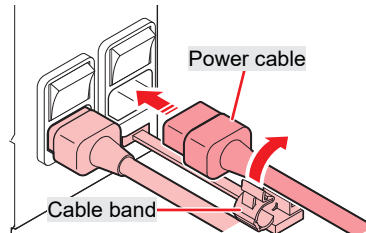

- 5** Plug the power plug into the power outlet.

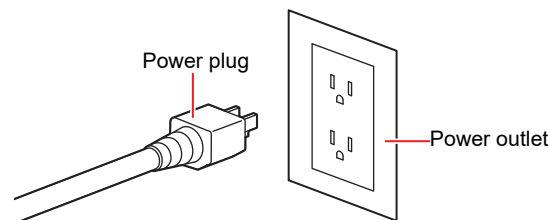

- Do not handle the power plug with wet hands. Disregarding this precaution may result in electric shock.

Turning On the Power

- 1** Check to confirm that the main power supply is turned on.
 - If the main power supply switch is not turned on, set to "I".

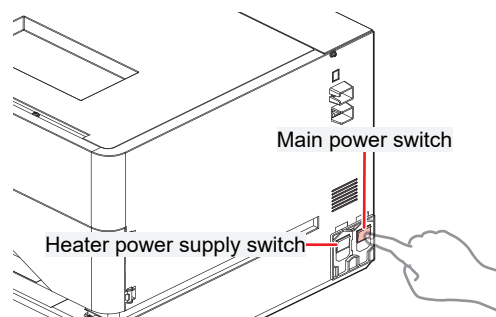

2 Hold down the [END/POWER] key to turn on power. (Press the key until the red LED on the upper right side illuminates.)

- The firmware version appears on the display, and the initial operation is executed. The machine will then enter the Media Select mode, and is ready for use.

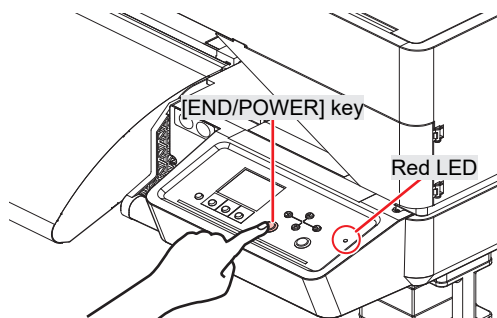

3 Turn on the power for the connected PC.



- Close the front cover. Leaving any of the covers open will disable the automatic maintenance function (including nozzle clogging prevention function and waste ink draining channel cleaning function). This will increase the risk of failure or ejection failures (e.g., nozzle clogging or deflection).

Turning Off the Power



- Check the following when turning off power:
 - (1) The front cover is closed.
 - Leaving any of the covers open will disable the automatic maintenance function (including nozzle clogging prevention function and waste ink draining channel cleaning function).
 - (2) The carriage has returned to the capping station.
 - If not, the print head nozzle may dry out, resulting in ejection failures (such as nozzle clogging or deflection).
 - (3) Data is not being received
 - (4) No errors have occurred.
 - Problems Causing Messages to Appear

1 Turn off the power to the PC connected.

2 Hold down the [END/ POWER] key.

- A power off confirmation screen appears. Press the [ENTER] key to turn the power off.



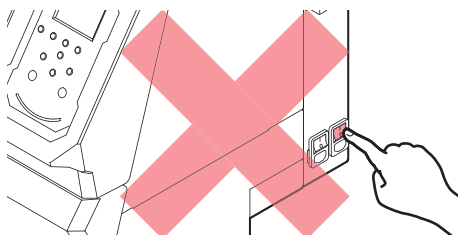

- Do not turn off the main power supply. Turning off the main power supply will disable the automatic maintenance function (including nozzle clogging prevention function and ink discharge channel cleaning function). This increases the risk of ejection failures (such as nozzle clogging or deflection).



1.3 Connecting a PC to the Product

Connect the machine to the RIP PC. The following cables can be used:

1.  ["Using a LAN Cable"\(P. 33\) \(Recommended\)](#)
2.  ["Using a USB Cable"\(P. 34\)](#)

Important! When using the USB cable

- Data may be transferred to the machine too slowly, **causing the carriage to pause at the left-hand or right-hand end** during printing.

Using a LAN Cable

Connect a PC to this product using a LAN cable. Insert a LAN cable until it engages with a click.



- Do not unplug the cable while data is being transferred.

● Network Connection Precautions

Make sure the network is set up as follows: Printing is not possible if the network is not set up correctly.

- Use a Category 6 or higher LAN cable.
- The PC used to transfer print data must be located on the same network as this product. This product cannot be connected via a router.
- Use a 1000BASE-T compatible computer or switching hub. Printing requires 1000BASE-T support.

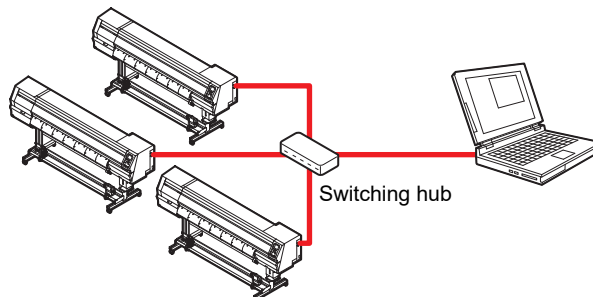

● Checking the LAN connection

1 Check the display on this product.

- Local guidance can be used for checking.  ["Displaying Machine Information \(Local Guidance\)"\(P. 30\)](#) Printing is not possible if "100Mbps", "10Mbps", or "No Connect" is displayed.

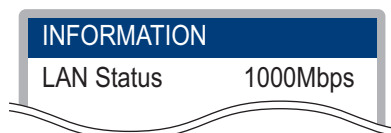

2 Check the lamp on the LAN connector.

- The LAN connector lamp illuminates when the machine is running.

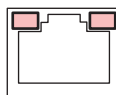

Color	Status	Overview
Green	Illuminated	Connected via 1000BASE-T
	Off	Connected via a network other than 1000BASE-T <ul style="list-style-type: none"> 1,000 Mbps is not supported if only the orange lamp is illuminated or flashing. Check the specifications for the PC, peripheral devices, and cable.
Orange	Illuminated	Linked up (connected).
	Flashing	Data being received
	Off	Link down (not connected)

Using a USB Cable

Connect a PC to this product using a USB interface cable.



- Do not unplug the cable while data is being transferred.



- Use RIP software that supports the USB interface.



- If the computer has no USB port, contact your local dealer or our service office.



When using the USB cable

- Data may be transferred to the machine too slowly, **causing the carriage to pause at the left-hand or right-hand end** during printing.

● USB Connection Precautions

- When connecting more than one CJV200 series to a PC
 - If the PC has more than one USB port, try connecting to a different USB port to check whether the product is correctly recognized. If the product is still unrecognized even when connected to a different USB port, use a commercially-available USB active repeater cable.
- When extending the USB cable
 - Use a commercially-available USB active repeater cable. However, make sure that the combined length of the USB cable and the USB active repeater cable does not exceed 20 m.
 - If the USB cable is extended, this may reduce the data transfer speed to the machine, causing the carriage to pause at the left-hand or right-hand end during printing.
- USB high-speed mode peripheral devices
 - It may not be possible to recognize USB peripheral devices if USB high-speed mode peripheral devices (e.g., USB memory, USB HDD devices) are connected to the PC to which the product is connected. If external USB hard disk drives or other similar devices are connected, this may reduce the data transfer speed to the machine, causing the carriage to pause at the left-hand or right-hand end during printing.
- Unplugging USB memory devices
 - When unplugging USB memory devices from the PC to which this product is connected, use "Stop" in "Safely removing hardware" before unplugging. Otherwise, an [ERROR 201 Command Error] will occur.

1.4 System Configuration

Use RIP software to request to print data created using applications like Illustrator or Photoshop.

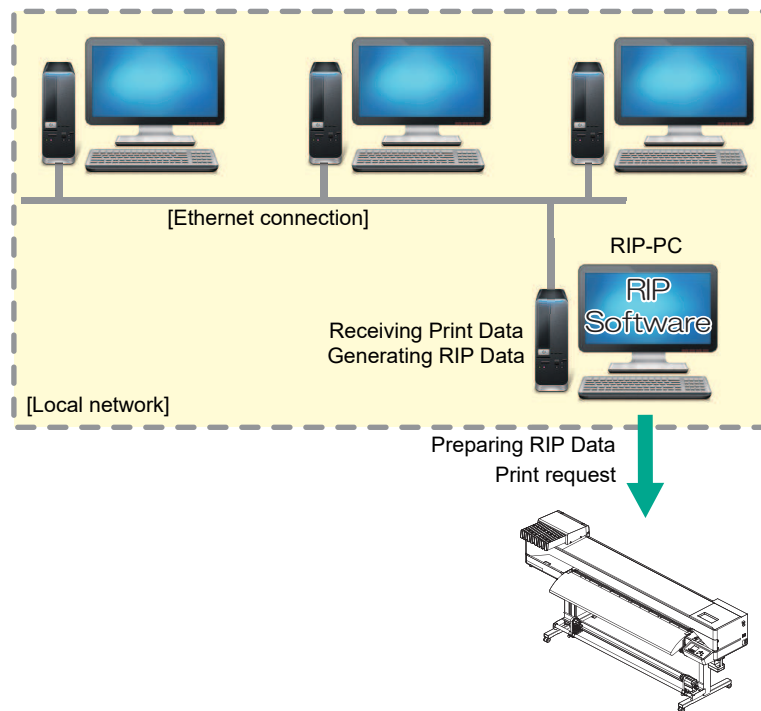

Installing the Mimaki Driver

1 Download the Mimaki driver from our website.

- <https://mimaki.com/download/inkjet.html>
[(Example: CJV200-160)] > [Driver/Utility]

2 Install the MIMAKI driver.

Installing RIP Software

The explanation here applies to MIMAKI RIP software (RasterLink).

1 Install RasterLink.

- The following icon appears on the PC desktop once the software has been installed.



- For more information, refer to the RasterLink installation guide. <https://mimaki.com/download/software.html>



- Once installed, activate the license for Rasterlink. Otherwise, "Profile Update" will not start.

Obtaining Color Profiles

Print quality (e.g., tone, bleeding) will vary depending on the media and ink set. To maintain consistent print quality, select a color profile that suits the media and ink set.

- The RasterLink Series includes a function allowing color profiles to be downloaded and installed directly from the Internet. For more information, refer to "Installing Profiles" in the RasterLink Series installation guide.
<https://mimaki.com/download/software.html>
[RasterLink Series used] > [Manuals]
- Color profiles for Mimaki RIP software (RasterLink) are available on the Mimaki website.
<https://mimaki.com/download/inkjet.html>
[(Example: CJV200-160)] > [Profile]

Setting Up RIP Software

The explanation here applies to MIMAKI RIP software (RasterLink).

1 Launch RasterLink.

- The [Printer Management] screen appears.
- To add a new model, launch RasterLink, then select [Environment] > [Printer Management].

2 Register the machine name (Example: CJV200-160).

(1) Click [Add].

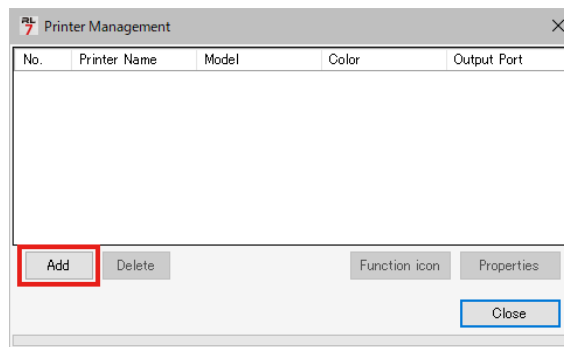

(2) Set the specifics for the machine.

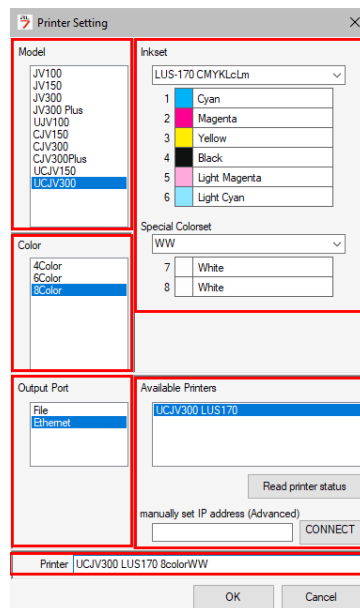

- Model: Select the model.
 - Color: Select the ink set filled.
 - Output Port: Select the cable connected.
 - Available Printers: Select CJV200-160 connected.
 - Printer: Enter a name as required.
- (3) Click [OK].
- A confirmation screen appears.
- (4) Click [Yes].
- Printer registration starts.



- For more information, refer to the RasterLink installation guide. <https://mimaki.com/download/software.html>

1.5 Ink Replacement Method

When Ink Near End is Displayed

Ink levels are low. We recommend replacing with new ink as soon as possible, because the ink packs are nearly empty. Printing is still possible but continuous printing is not, and some maintenance functions such as cleaning are disabled. Note that ink may run out during printing.

To check which color ink needs to be replaced, press the [ENTER] key on the LOCAL mode screen.  ["Displaying Machine Information \(Local Guidance\)"\(P. 30\)](#)

When Ink End is Displayed

The ink has run out. Replace with new ink.

Thoroughly read the following and make sure you understand its contents.

 ["Notes on Handling Ink or any Other Liquid Used with the Machine"\(P. 13\)](#)



- Pay close attention to ventilation and be sure to wear safety glasses, gloves, and a mask when handling ink, maintenance liquid, waste ink, or other solutions used with the machine. Leaking ink may adhere to the skin or get into the eyes or mouth.



Replacing Ink

● Remove the Ink pack

1 Remove the ink cartridge.

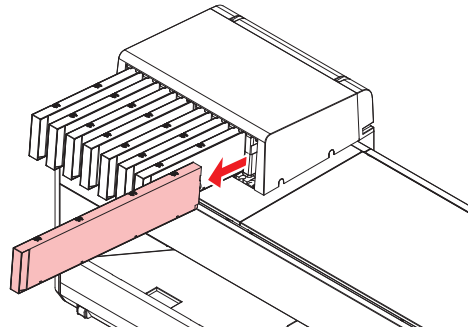

● Mount the Ink pack

The order of Ink pack to be set depends on the ink set you are currently using. Check the ink slot numbers and insert the correct color Ink pack.

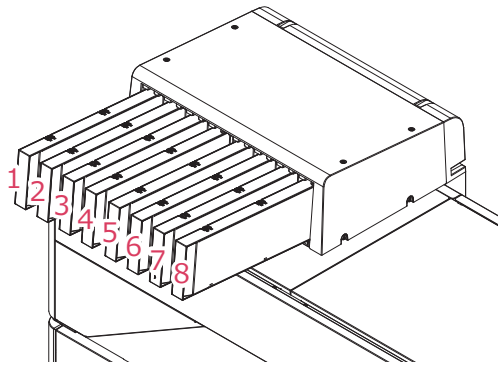

Ink set	Ink positions							
	1	2	3	4	5	6	7	8
4-color (C, M, Y, K)	M	M	C	C	Y	Y	K	K
8-color (C, M, Y, K, Lc, Lm, Lk, Or)	M	Or	C	Lk	Y	Lm	K	Lc

1 Insert the ink cartridge.

- Insert the ink cartridge with the ink IC chip facing left.

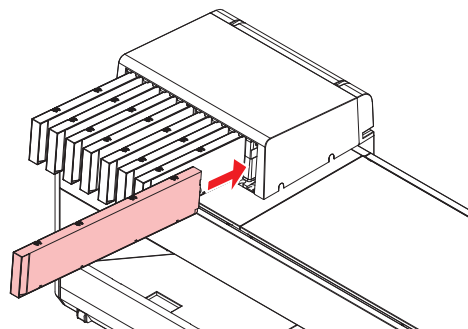

- Fully push in the eco-case. Otherwise, ink may not be fed properly.



- Do not touch the metal parts of the ink IC chip. Static electricity may damage the ink IC chip, and dirt or damage may cause the ink IC chip read error.
-

Chapter 2 Printing



This chapter

This chapter describes printing procedures and settings.

Print Process	42	Test Printing	67
Adjusting Print Head Height	45	Changing the Layout Direction for Test Printing	67
Adjust the Pinch Roller Positions.	46	Ejection Failures	68
1,600 mm Size	47	Head Cleaning.....	69
1,300 mm Size	48	Auto Correction	70
750 mm Size	49	Feed Correction.....	71
Loading the Media	50	Feed Correction Procedure.....	71
Media	50	Correcting the Drop Position	73
Take-up unit	51	Drop Position Correction Procedure	73
Feeding unit	53	Preparing RIP data	75
Loading the Roll Media	55	Printing	77
Setting Leaf Media	60	Changing the origin	77
Registering the Media	63	Starting Printing	78
Setting the Pressure and Number of Pinch Rollers to Use	65	Stopping Printing (Data Clear)	79
Setting the Heater Temperature	66	Cutting the media	80

2.1 Print Process

1. Turn on the power.

 ["Turning On the Power"\(P. 31\)](#)

2. Connect a RIP PC to the machine.

 ["Using a USB Cable"\(P. 34\)](#)

 ["Using a LAN Cable"\(P. 33\)](#)

3. Setting Up RIP Software

 ["Installing RIP Software"\(P. 36\)](#) (required first time only)

 ["Obtaining Color Profiles"\(P. 36\)](#)

 ["Setting Up RIP Software"\(P. 36\)](#) (required first time only)

4. Adjusting Print Head Height

Adjust the height adjustment lever to suit the media.  ["Adjusting Print Head Height"\(P. 45\)](#)

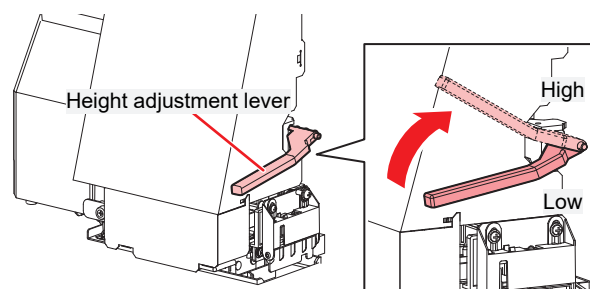

5. Adjust the Pinch Roller Positions.

Adjust the pinch roller positions to suit the width of the set media. Adjust the pinch roller positions so that the pinch rollers are positioned above the grit rollers. The pinch rollers at both ends should be aligned to within 10 cm from the left edges and 2 cm from the right edges of the media.  ["Adjust the Pinch Roller Positions."\(P. 46\)](#)

6. Loading the Media

This machine can be used with roll media and leaf media.  "Loading the Media"(P. 50)

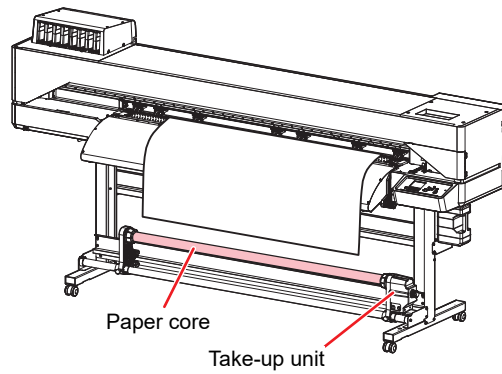

7. Adjust the number and pressure of pinch rollers to use.

Set an appropriate pressure for the set media.  "Setting the Pressure and Number of Pinch Rollers to Use"(P. 65)

8. Setting the Heater Temperature

 "Setting the Heater Temperature"(P. 66)

9. Check the state of the print head nozzles.

 "Test Printing"(P. 67)

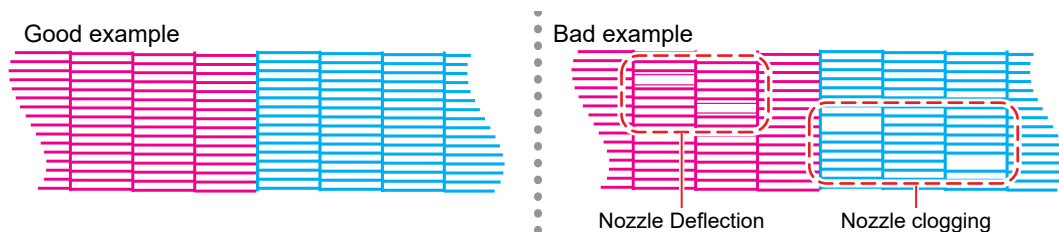

10. Clean the head to clear malfunctioning nozzles.

There are three different head cleaning methods. Choose the head cleaning method based on test print results.  "Head Cleaning"(P. 69)

11. Adjust the media feed amount.

 "Feed Correction"(P. 71)

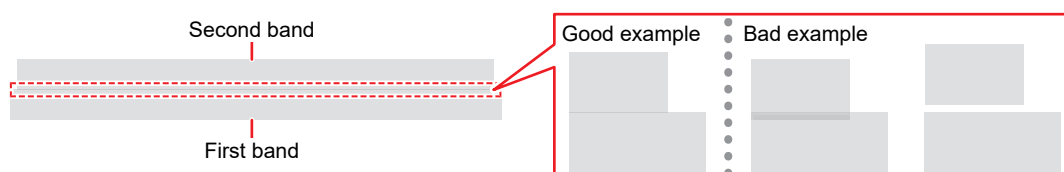

12. Adjust the drop position for bi-directional printing.

☞ "Correcting the Drop Position"(P. 73)

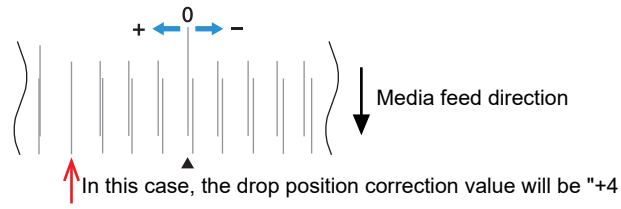

13. Preparing RIP data

☞ "Preparing RIP data"(P. 75)

14. Printing RIP data

☞ "Printing"(P. 77)

15. Cutting the media

☞ "Cutting the media"(P. 80)

2.2 Adjusting Print Head Height

Adjust the height of the print head according to the thickness of the media you are using.

Range	Gap between print head and platen
Low (recommended)	1.5 mm (default setting)
High	2.0 mm



- Be sure to correct the dot position after altering the print head height.  "Correcting the Drop Position"(P. 73)



- With inkjet printers, if the gap between the print head and media increases, the ink droplets tend to vaporize before they reach the media. Vaporized ink may adhere to the print head nozzle surface and media, affecting print quality and causing failure of the print head. Adjust the print head height to suit the media.

- 1 On the LOCAL mode screen, select [MENU] > [Maintenance], then press the [ENTER] key.
 - The Maintenance menu is displayed.
- 2 Select [Station Maint.] > [Carriage Out] > [Head height switching], then press the [ENTER] key.
 - The carriage moves over the platen.
- 3 Use the height adjustment lever to adjust the height.
 - Adjust the height adjustment lever so that it is at the desired height. If the lever is not set to the correct position, problems such as media jamming and misting may occur, resulting in impaired print quality.

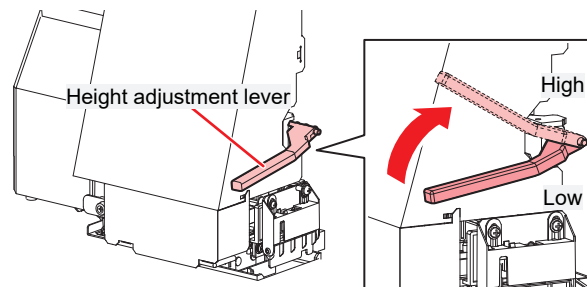

- 4 Press the [ENTER] key.
- 5 Select [LOW/HIGH] on the screen, then press the [ENTER] key.

2.3 Adjust the Pinch Roller Positions.

Adjust the pinch roller positions to suit the width of the media being used.

- 1 Choose the grit rollers capable of holding down the media at equal intervals.

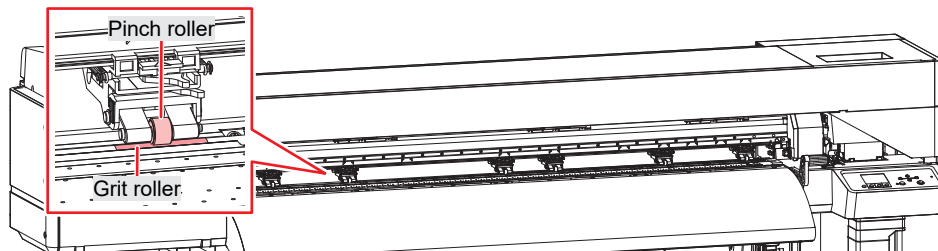

- 2 Move the pinch rollers above the grit rollers.

- Use the pinch roller guide marks as references.



- When adjusting from the front

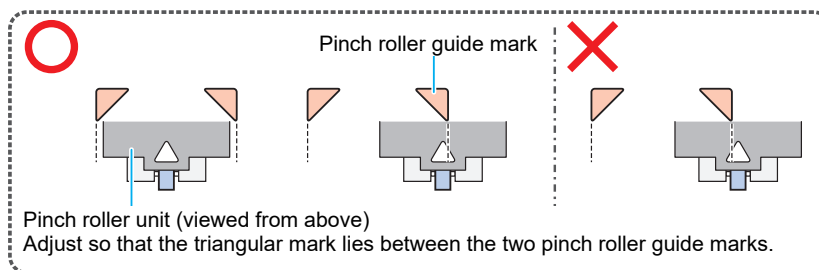

- When adjusting from the rear

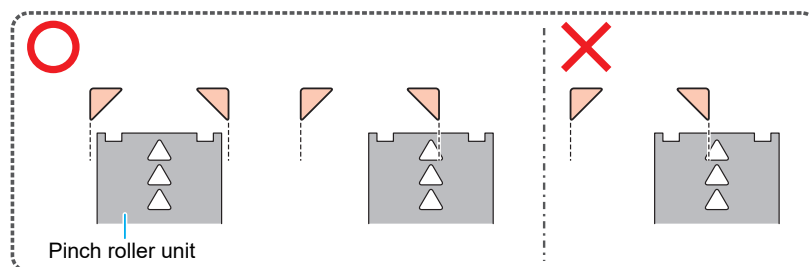

- 3 Align the pinch rollers at both the ends to within 10 cm from the left edges and 2 cm from the right edges of the media.

- Placement farther from the edges may leave some portions of the media uncut.

- 4 Manually set the pressure of the pinch rollers lying outside the media to "Low", and remove the pinch rollers from the grit rollers.

- The pinch roller pressure is set to "Low" by moving the handle shown in the diagram below to left.

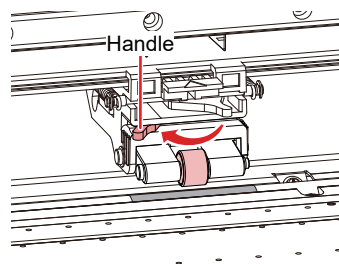

- Feeding media with the pinch rollers and grit rollers in contact will cause pinch roller wear.

1,600 mm Size

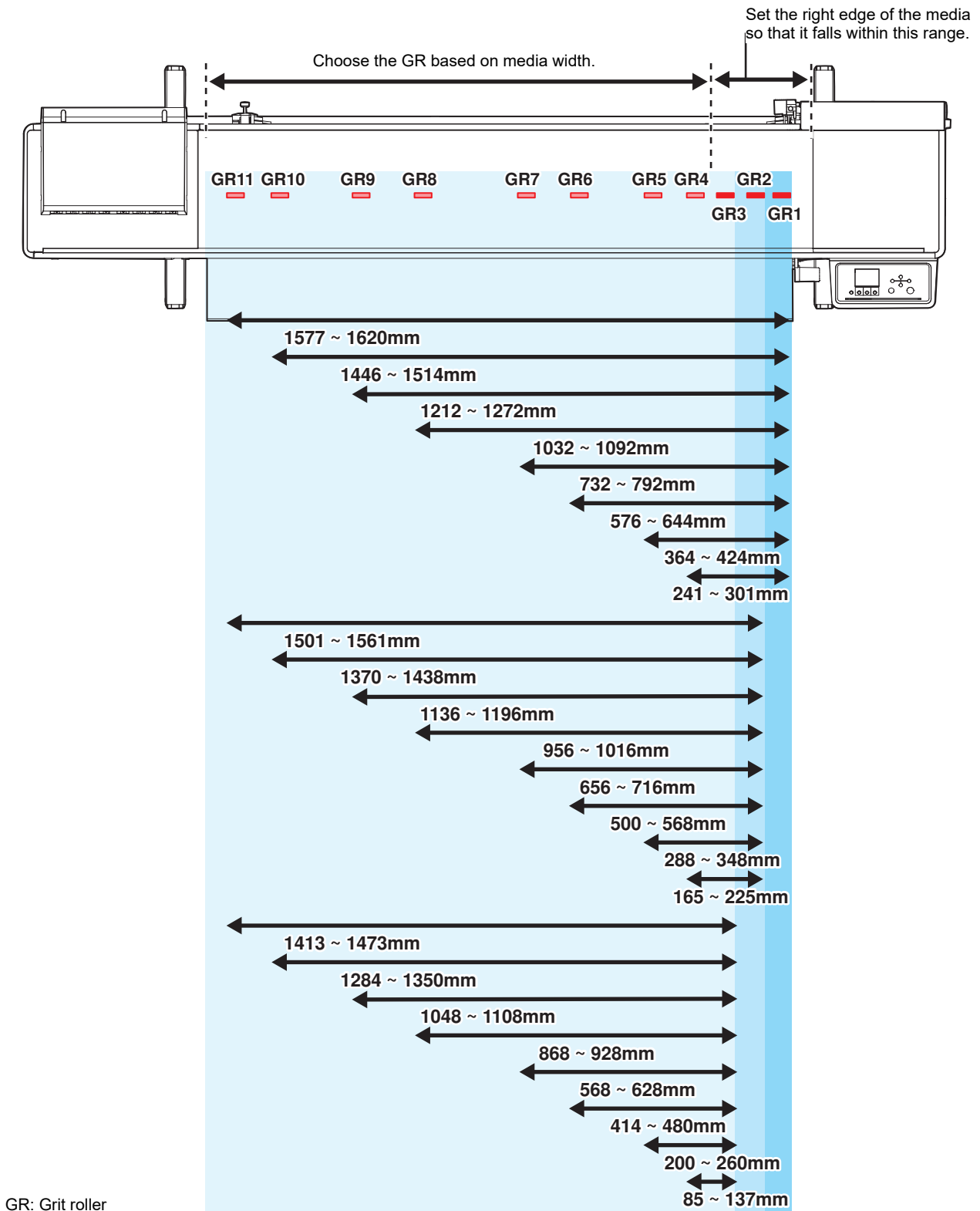

1,300 mm Size

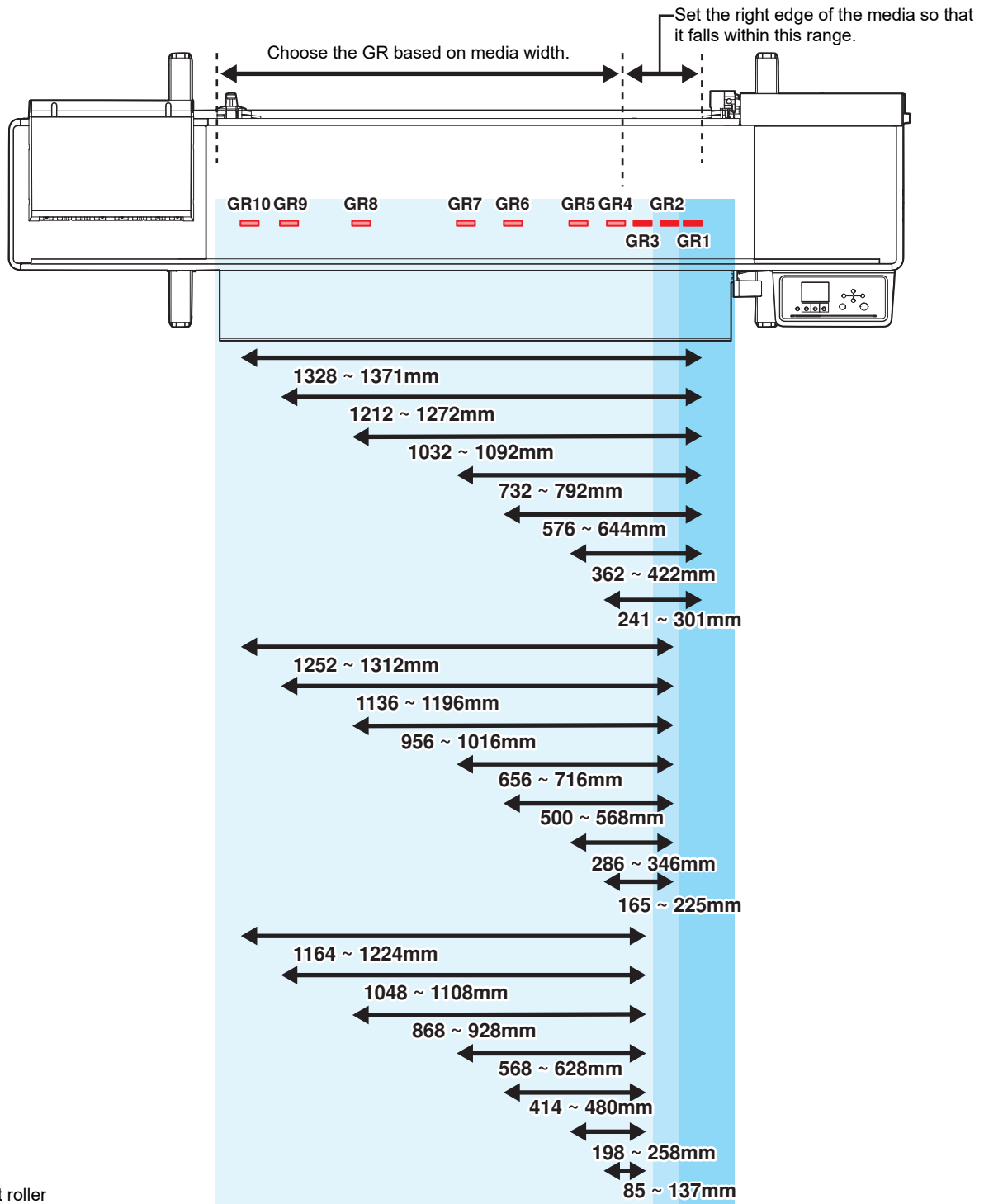

750 mm Size

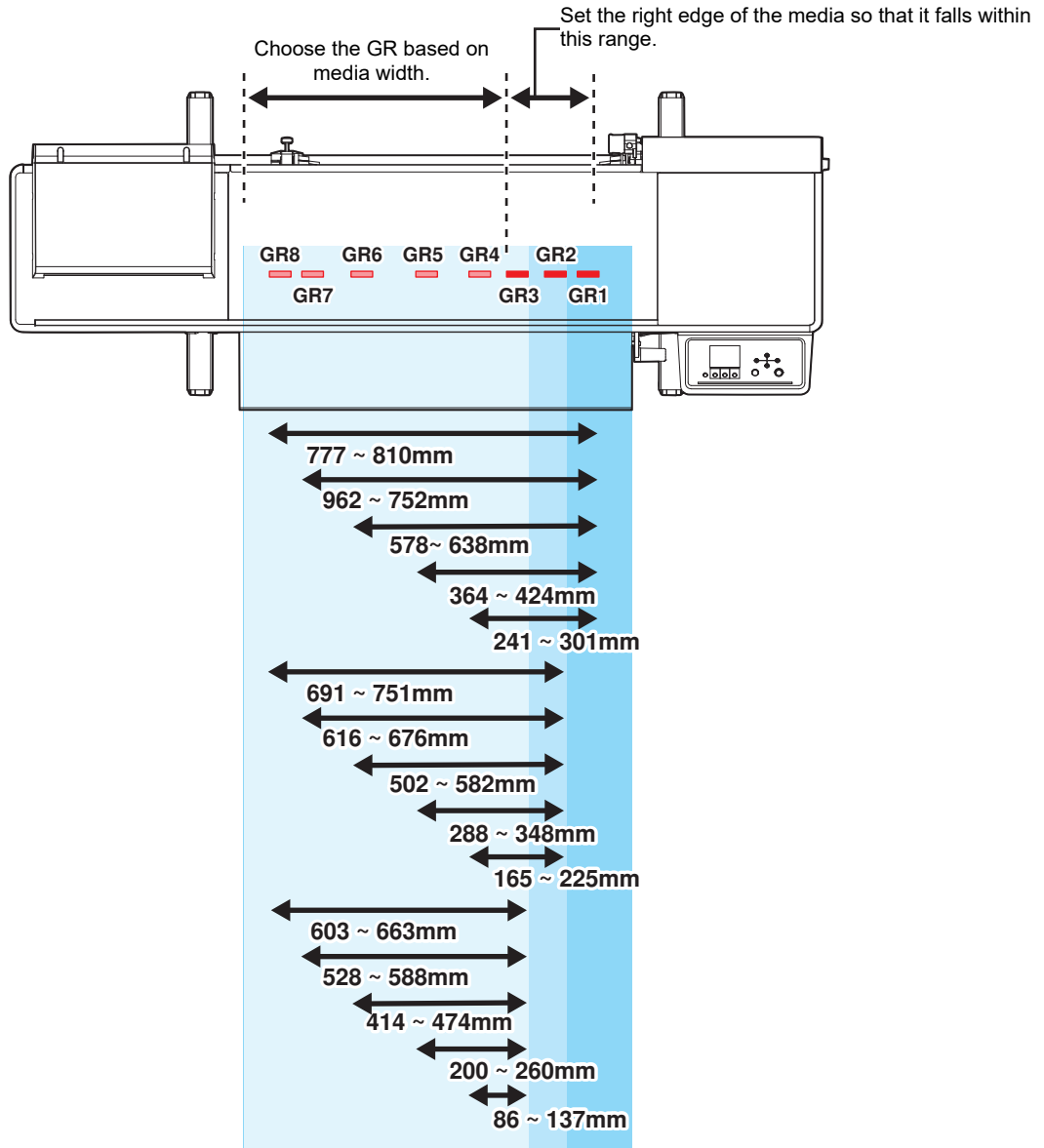

GR: Grit roller

2.4 Loading the Media



- Adjust the head height before loading media. Moving the carriage after the media has been loaded may result in the print head coming into contact with the media and being damaged.

Media

● Media handling precautions



- Use Mimaki-approved media to ensure consistent high-quality printing.

WARNING



- Assign at least two persons to load roll media. Disregarding this precaution may result in low back pain due to the weight of media.

NOTICE



- Protect media from dust when stored. Otherwise print quality may be reduced.
- When storing standard-size media rolled up, store with the coated surface facing out.



- Do not leave the media in the machine when not in use. Otherwise dust may accumulate on the media. Do not use media that has been wiped free of dust. Wiping media can generate static electricity, possibly affecting print quality.
- Do not use media immediately after removing it from the package. The media may expand or contract depending on the temperature and humidity of the location in which it was stored. Allow the media to stand for at least 30 minutes in the same indoor environment as the machine before loading it.
- Do not use media if it is curled. Curled media may not only damage the print head, but may also affect print quality.



- The underside of the media may be soiled depending on how the printed media has been stored (due to weight when laying printed media rolls horizontally, for example) and the media type. Perform a test beforehand to check that the media does not transfer ink to the underside of the adjacent media.

Take-up unit

Use the switch on the take-up unit to change the media take-up direction.

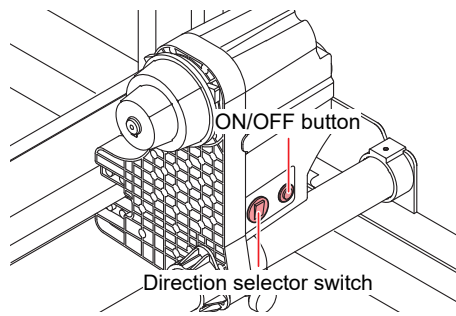

Name	Overview	
Direction selector switch	Up	To take up media with printed surface on the inside
	Down	To take up media with printed surface on the outside
ON/OFF button	Press the button to start/stop the take-up unit. The setting can be altered so that the take-up unit operates only while the button is depressed. Function Setting Menu	

Adjusting the Torque Limiter

The left and right take-up units are fitted with a torque limiter.

Turn the torque limiter adjustment nut to adjust take-up tension. When adjusting the torque limiters, be sure to adjust to the same torque for both the left and right take-up units.

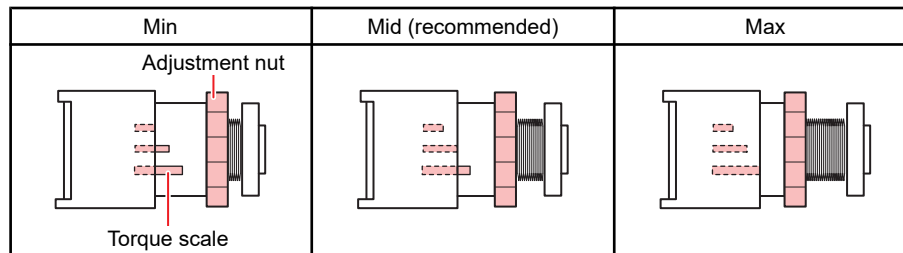

- For normal printing: Adjust the torque to "Mid".
- Depending on the media, increasing the torque may cause image defects due to the pinch roller and grit rollers failing to grip the media. Reduce the torque if the media slips.

● Increase tension (clockwise)

Increase tension when using with heavy or thick media, such as tarpaulin. Perform adjustments manually.

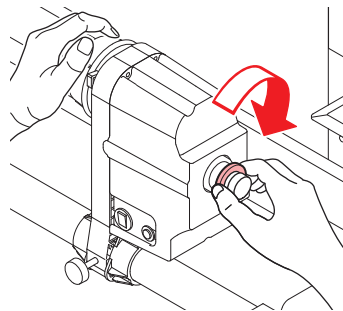

- Do not use the torque adjustment handle. Using the torque adjustment handle will cause overtightening. Overtightening may damage the take-up unit.

● Decrease tension (counterclockwise).

Decrease tension when using lightweight media. Use the "torque adjustment handle" provided.

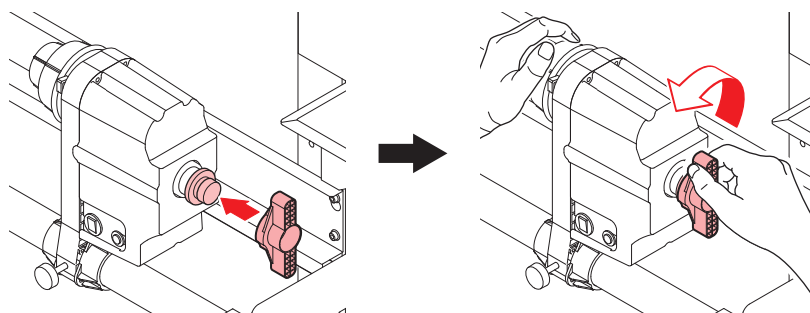

Feeding unit

Using the Media Stopper

When pulling out a fixed length of media by hand, the roll holder locks, stopping the media from being pulled out.

● Lock the media stopper

Push the side pin while pressing on the media stopper. Releasing the media stopper in this state locks the roll holder.

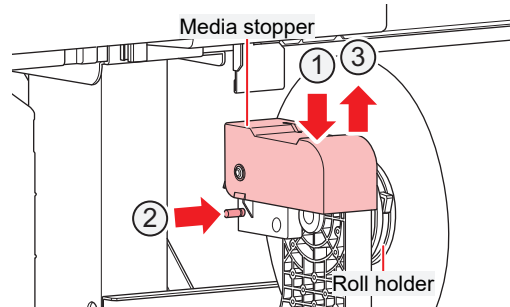

- Be sure to lock the media stopper when loading roll media or printing.

● Release the media stopper

Press the media stopper to release the roll holder.

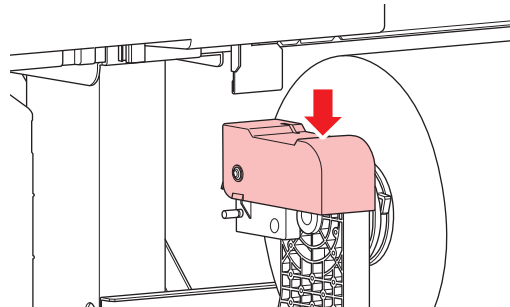

Roll Holder Setting Position

Loosen the knob screw on the rear left roll holder, then move it to the roll setting position.

Use the pinch roller guide marks as references to move the roll holder, then secure using the knob screw.

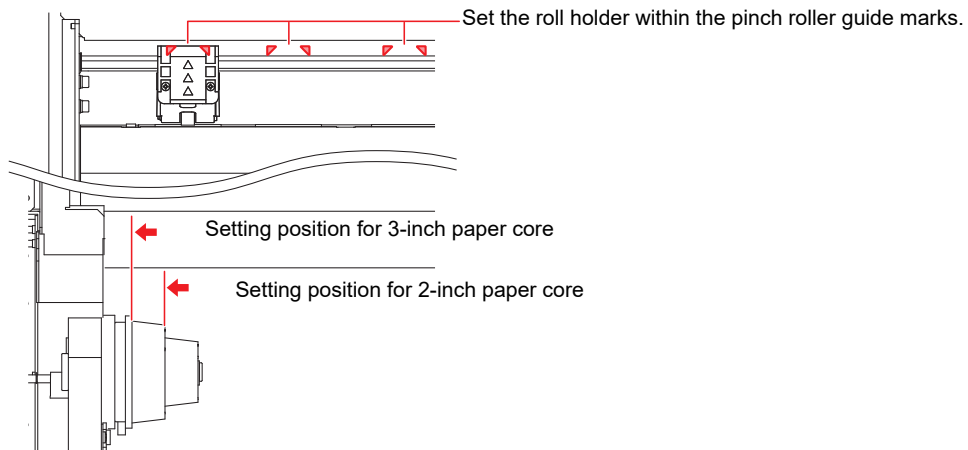

Loading the Roll Media

1 Raise the clamp lever.

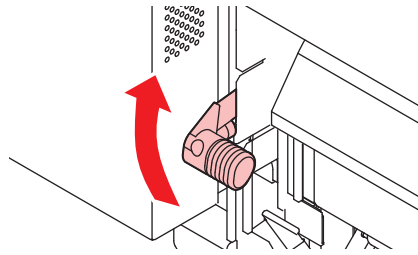

2 Move the rear left roll holder to the roll setting position.

- Unscrew the roll holder retaining screw, move the roll holder, then retighten the retaining screw.
 ["Roll Holder Setting Position"\(P. 54\)](#)

3 Insert the paper core of the roll media on to the rear left roll holder.

- Push in until the paper core moves no farther.

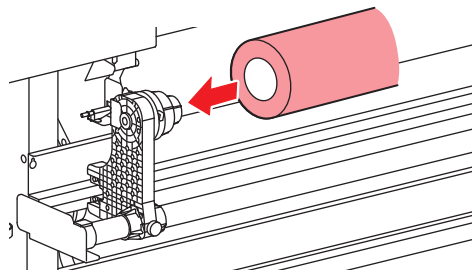

4 Insert the rear right roll holder into the paper core.

- Unscrew the roll holder retaining screw, move the roll holder, then retighten the retaining screw.

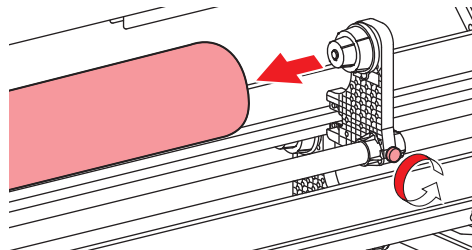

5 Insert the media between the pinch rollers and the grit rollers.



- Inserting the media at an angle allows smooth insertion without catching or sticking.

6 Lower the clamp lever.

- Hold the media with the pinch roller and grit rollers.

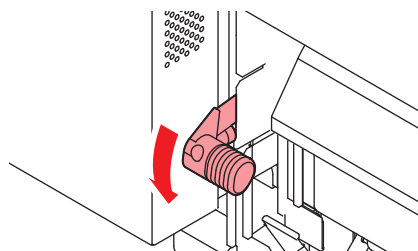

7 Lock the media stopper.

-  ["Using the Media Stopper"\(P. 53\)](#)

8 Move to the front of the machine, raise the clamp lever and pull out the media.

- Make sure the media does not fall to the rear.



- Adjust the rear roll holder position so that the media does not cover the right-hand slit line on the platen. Movement at an angle may result in damage to the print head.

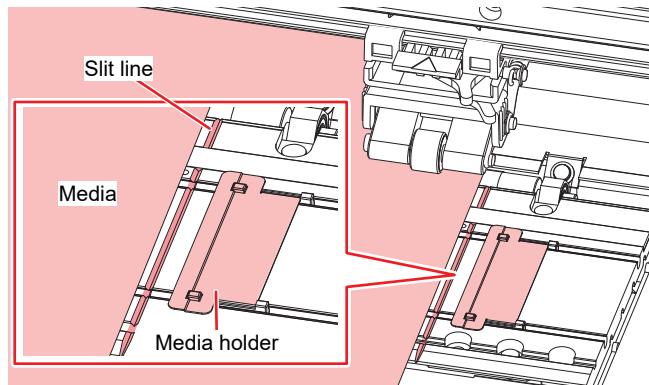

- The areas extending 5 mm from both sides of the media are margins.

9 Lower the clamp lever to confirm that the spacing from the pinch roller is uniform.

-  ["Adjust the Pinch Roller Positions."\(P. 46\)](#)

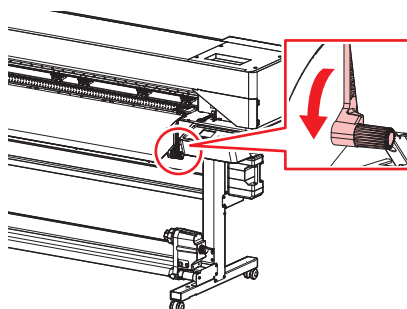

- If the spacing is not uniform, repeat all steps from the start.

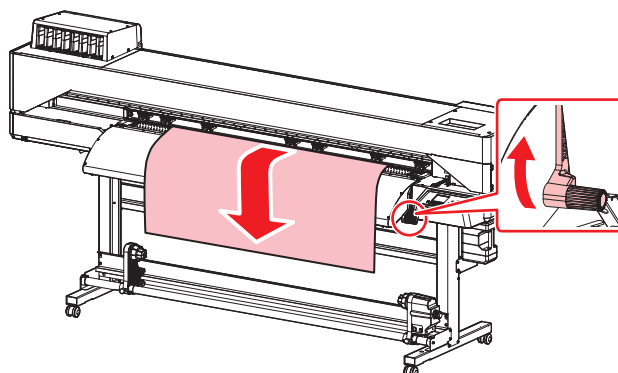
10 Raise the clamp lever.**11** Gently pull out the media and stop at the position where it is gently locked in place.

12 Check how far the media was pulled out.

- Pull the front edge of the media gently at several points to confirm that the media was pulled out by the same amount.

13 Lower the clamp lever.



- Do not pull the media when the clamp lever is lowered (the media is clamped). Doing so may damage the machine.

14 Secure the media in the media holder.

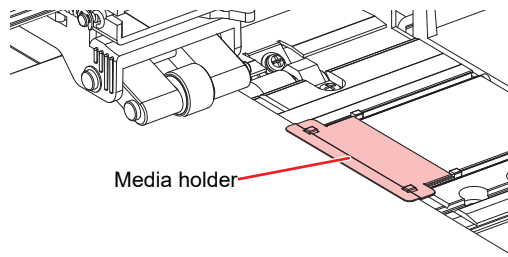

- Do not use the media holder when printing on thicker media.
- Do not use the media holder when cutting media.
- Use the media holder when detecting media.

15 Select the media to be used.

Media selection	1/2
• PVC	1300 mm
○ Tarpaulin	1600 mm
○ Unregistered	
○ Unregistered	
○ Unregistered	



- To use unregistered media, select [Unregistered] to register the media. ["Registering the Media"\(P. 63\)](#)

16 Detect the media width.

- No change: Only the right side of the media holder is detected.
- Media width re-detection: The media width is detected.

PVC	
Media Width	1300 mm
	No change Media width



- Media width may not be detected correctly for certain colors or types of media. When media width cannot be detected correctly, set the media width detection method to "MANUAL".
- If the media width detection method is set to "MANUAL", set the media width manually ([MENU] > [Media Setting] > [Media Information] > [Media Width] > [Detection Type] Media Setting Menu).
- A notification reading "Media Set Position R" will appear after media width detection if the media is too far to the right of the specified position. Reload media in the specified position.
- If Media Remain Manage is set to "ON", the Input Media Length screen will be displayed. ([MENU] > [Media Setting] > [Media Information] > [Media Remain] > [Media Remain Manage] Media Setting Menu).

17 Enter the number of pinch rollers being used.

- If the setting for [Function Setting] > [Use PR Number Query] is "OFF", the screen for entering the number of pinch rollers will not be displayed.

18 Load an empty paper core on the take-up unit.

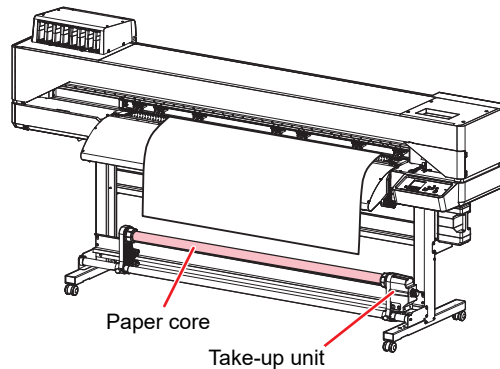

- Use the take-up unit for media with low stiffness (such as tarpaulin). If not, the media may rise up on the platen and damage a print head.

19 Press to feed the media until it reaches the paper core on the take-up unit, then press the [ENTER] key.

20 Secure the middle of the media to the paper core with adhesive tape, then secure the left and right sides of the media.

- Pull the lower edge of the media evenly on both the left and right sides, check to confirm that it is free of sagging and creasing, then affix the tape.

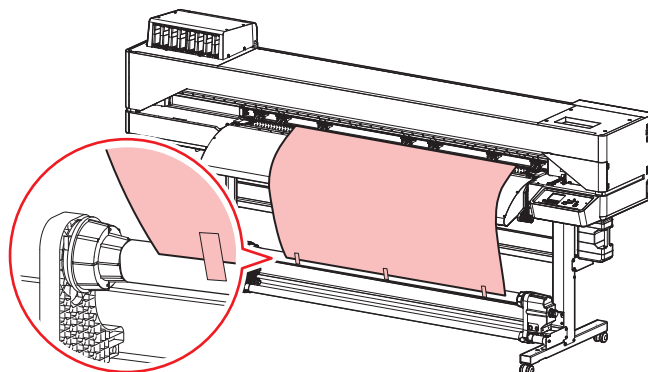

21 Press to wrap the media about one and a half turns around the paper core, then press the [ENTER] key.



- Move the take-up unit to the left or right when it is not in use. Print quality may be affected if the front edge of the media hits the take-up unit.

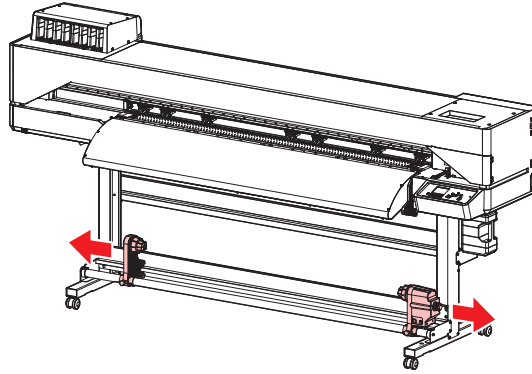

Setting Leaf Media



- Move the take-up unit out of the way to the left and right when it is not in use. Print quality may be affected if the front edge of the media hits the take-up unit.

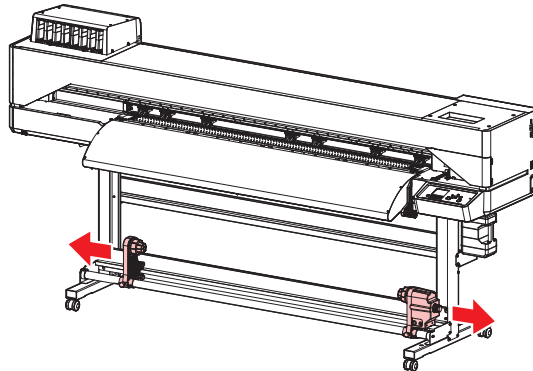

- 1 On the LOCAL mode screen, select [MENU] > [Media Setting], then press the [ENTER] key.
 - The Media Setting menu is displayed.

- 2 Select [Media Information] > [Media Operation Form] > [Leaf], then press the [ENTER] key.



- The media bottom end will not be detected if Leaf is not selected.

- 3 On the LOCAL mode screen, select [MENU] > [Media Setting], then press the [ENTER] key.

- 4 Raise the clamp lever.

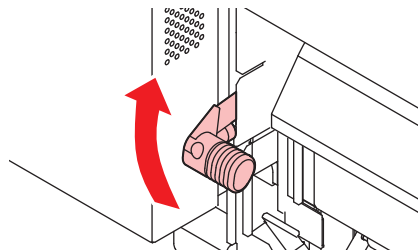

- 5 Insert the media.

- Insert into the gap between the pinch rollers and the grit rollers.



- Inserting the media at an angle allows smooth insertion without catching or sticking.

6 Adjust the position of the right media edge.

- Set the media straight so that the media does not lie beyond the slit line on the platen.

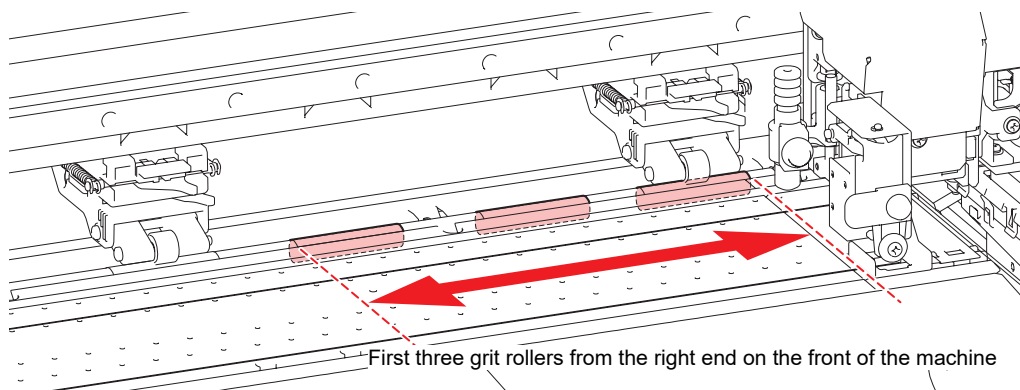

- The areas extending 5 mm from both sides of the media are margins.

7 Adjust the position of the front media edge.

- Set the media so that about 40 mm of it lies on the after cover. If not, the media width may not be detected.

8 Lower the clamp lever to confirm that the spacing from the pinch roller is uniform.

- Hold the media with the pinch roller and grit rollers.
-  ["Adjust the Pinch Roller Positions."\(P. 46\)](#)

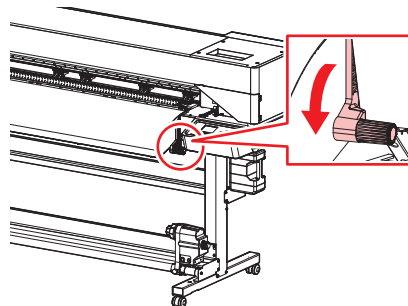

- If the spacing is not uniform, repeat all steps from the start.

9 Secure the media in the media holder.

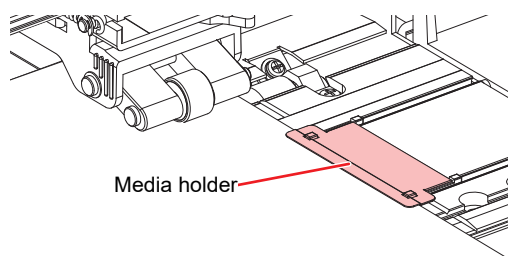

- Do not use the media holder when printing on thicker media.
- Do not use the media holder when cutting media.
- Use the media holder when detecting media.

10 Select the media to be used.

Media selection		1/2
<input checked="" type="radio"/>	PVC	1300 mm
<input type="radio"/>	Tarpaulin	1600 mm
<input type="radio"/>	Unregistered	
<input type="radio"/>	Unregistered	
<input type="radio"/>	Unregistered	



- To use unregistered media, select [Unregistered] to register the media. ["Registering the Media"\(P. 63\)](#)

11 Detect the media width.

- No change: Only the right side of the media holder is detected.
- Media width re-detection: The media width is detected.

PVC	
Media Width	1300 mm
	No change Media width



- Media width may not be detected correctly for certain colors or types of media. When media width cannot be detected correctly, set the media width detection method to "MANUAL".
- If the media width detection method is set to "MANUAL", set the media width manually ([MENU] > [Media Setting] > [Media Information] > [Media Width] > [Detection Type] Media Setting Menu).
- A notification stating "Media Set Position R" will appear after media width detection if the media holder is too far to the right of the specified position. Reload media in the specified position.

12 Detect the media bottom.

- Select [Execute].

Media detect	
Start detecting the media trailing edge.	
	Execute Not execute

13 Enter the number of pinch rollers being used.

- If the setting for [Function Setting] > [Use PR Number Query] is "OFF", the screen for entering the number of pinch rollers will not be displayed.

Registering the Media

When the clamp lever is lowered with media being loaded, the Select Use Media screen is displayed. Registration is required to use media that is not registered on the machine.

1 Select [Unregistered].

Media selection	1/2
<input checked="" type="radio"/> PVC	1300 mm
<input type="radio"/> Tarpaulin	1600 mm
<input type="radio"/> Unregistered	
<input type="radio"/> Unregistered	
<input type="radio"/> Unregistered	

2 Select the media type.

Media Type
<input checked="" type="radio"/> PVC
<input type="radio"/> Tarpaulin
<input type="radio"/> Transfer paper
<input type="radio"/> Illuminated Film
<input type="radio"/> Cutting Sheet

3 Select the media width detection type.

- AUTO: The media width is automatically detected.
- MANUAL: The media width is manually set.

Media Detection Type
Please Select.
AUTO
MANUAL



- Media width may not be detected correctly for certain colors or types of media. When media width cannot be detected correctly, set the media width detection method to "MANUAL".

4 Select the media form.

- Select whether roll media or leaf media is used.

Media Operation Form
Please Select.
Roll
Leaf



- When [Roll] is selected, the Media Remain Manage screen is displayed.

5 Select the method for managing the media remaining amount.

- Select whether or not to manage the media remaining amount with the machine.

Media Remain Manage
Please Select.
ON
OFF

6 Enter the name to be displayed.

- If you do not register the name, press the [ENTER] key.

Media Name Change
Media 3 will be changed (maximum 10 characters)

7 Select whether or not to register the set information.

do you optimize setting?
Execute Do not



- You can change the settings later. Media Setting Menu
-

2.5 Setting the Pressure and Number of Pinch Rollers to Use

Set the pressure and number used to hold media based on the tool and media being used. Incorrect pinch roller pressure settings may result in media skew or leave pinch roller marks on the media.

- 1 On the LOCAL mode screen, select [PR].

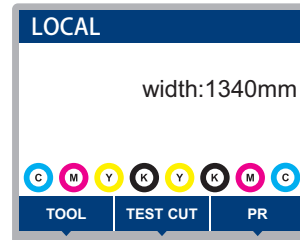

- 2 Make settings based on the tool and media used.

- The following items can be configured:
- The settings are retained even when the power is turned off.

Item	Setting	Overview
Number for Use	160: 2–7 130: 2–6 75: 2–4	Sets the number of pinch rollers to use.
Print	LOW/MID/HIGH	Sets the pressure used for printing. <ul style="list-style-type: none"> • Recommended value (normal): MID
Cut:Ends	LOW/MID/HIGH	Sets the pressure for both the pinch rollers on the edges (left and right) used for cutting. <ul style="list-style-type: none"> • Recommended value (normal): HIGH
Cut:Inner	OFF/LOW/MID/HIGH	Sets the pressure for the pinch rollers used for printing other than those on the edges. <ul style="list-style-type: none"> • Recommended value (normal): Low
Change Execution	-	Used to check settings. Switch to configured settings before printing the built-in pattern (e.g., test printing, test cutting).
Skip switching PR	OFF/ON	Sets automatic pinch roller switching not to be performed when data is received. Use [Change Execution] to switch pinch roller pressure.



When the machine is not in use, raise the clamp lever to **separate the pinch rollers from the grit rollers**.

- Leaving the pinch rollers lowered may cause them to become deformed and prevent media from being fed correctly.
- Leaving media loaded will subject it to force from the pinch rollers, which may leave pinch roller marks on it.

2.6 Setting the Heater Temperature

Set the heater temperature to suit the type of media used. The temperature can be altered while printing is in progress, but this may cause color variations to occur.



- Adjust the heater temperature to suit the media type and characteristics. Depending on the type, the media may expand or shrink or become rippled.



- The temperature setting in the RIP software takes precedence. If you are using the Mimaki RIP software (RasterLink), the recommended values are stored in the color profile.

Name	Overview
PRE (Preheater)	Preheats the media before printing to suppress rapid temperature change.
PRINT (Print heater)	Helps prevent ink bleeding.
POST (Post-heater)	Allows ink to dry after printing. <ul style="list-style-type: none"> • The temperature at the lower part of POST is lower than the upper part.

1 On the LOCAL mode screen, select [HEATER].

- The Heater Temperature Setup screen appears.

2 Enter the heater temperatures, then press the [ENTER] key.

- Printing is possible once the heater temperatures reach the temperature settings ± 3 °C.

2.7 Test Printing

Print a test pattern to confirm that the ink prints correctly. Perform head cleaning if you observe any ejection failures (e.g., nozzle clogging or deflection). 🖨️ "Head Cleaning"(P. 69)

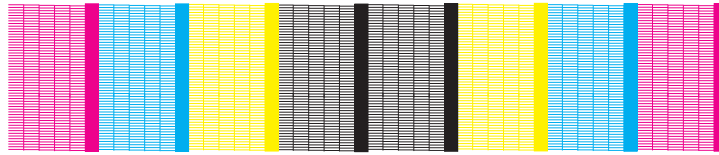

Check beforehand

- Was the print head adjusted? 🖨️ "Adjusting Print Head Height"(P. 45)
- Is media loaded? 🖨️ "Loading the Media"(P. 50)



- Load media at least 500 mm wide. You cannot print the entire pattern if media less than 300 mm wide is used.



- Select [Maintenance] > [Nozzle Recovery] > [Test Print], then select "ON" to perform nozzle recovery and test printing. Registration is required to perform nozzle recovery. 🖨️ "Registering Nozzle Recovery Manually"(P. 115)

Changing the Layout Direction for Test Printing

You can change the layout direction for test printing.

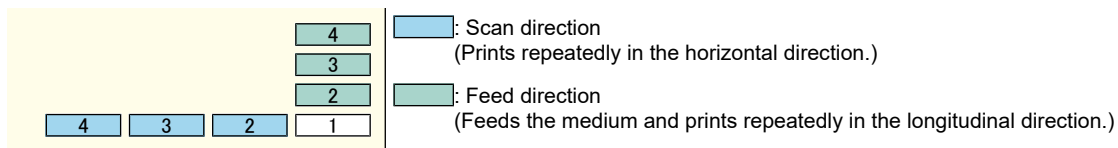

- 1 On the LOCAL mode screen, select [TEST PRINT/CLEANING] > [Test Print], then press the [ENTER] key.
 - The Test Print menu is displayed.
- 2 Select [Scan Dir.] or [Feed Dir.], then press the [ENTER] key.
 - Test printing starts.

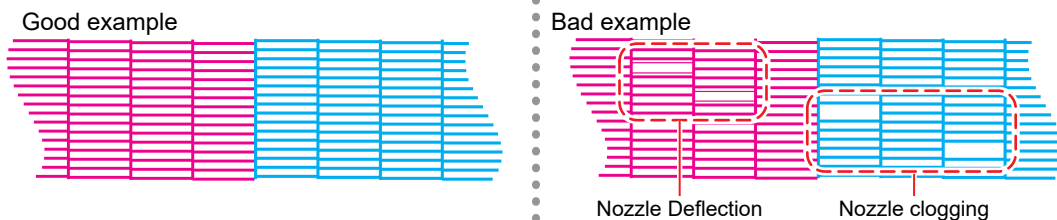

- 3 Check the print results.

Ejection Failures

Typical examples of ejection failures (e.g., nozzle clogging, deflection) are as shown below. In order to prevent printing in such a state, check whether the ink has been properly ejected regularly before printing.

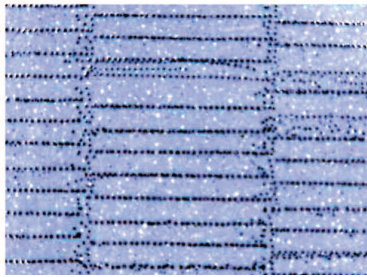

Nozzle Deflection

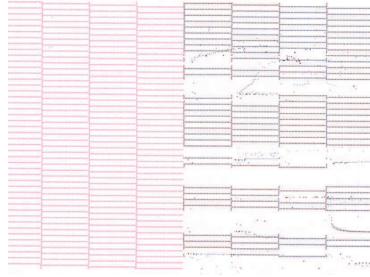

Nozzle clogging



Ink drips



Mist

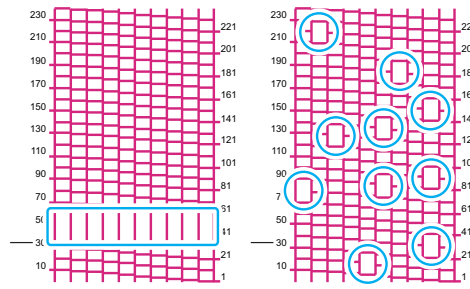

Mixed air

2.8 Head Cleaning

The following head cleaning methods are available. Choose the method based on test results. Cleaning is not possible when the [Ink Near End] or [Ink End] errors are displayed. Replace with new ink.  ["Replacing Ink"\(P. 39\)](#)

Item	Details
Soft	If the print shows a bent line (Nozzle deflection)
Normal	If the print shows a missing line (nozzle clogging)
Hard	If soft cleaning and normal cleaning fail to resolve ejection failures (e.g., nozzle clogging or deflection).

1 On the LOCAL mode screen, select [TEST PRINT/CLEANING] > [Cleaning], then press the [ENTER] key.

- The Cleaning menu is displayed.

2 Select the cleaning type, then press the [ENTER] key.

3 Run another test print and check the print results.

- Repeat the cleaning and test printing process until the print results appear normal.



- Do the following if head cleaning fails to resolve the ejection failures (e.g., nozzle clogging or deflection).

 ["Cap Rubber Cleaning"\(P. 130\)](#)

 ["Print Head Nozzle Washing"\(P. 161\)](#)

 ["Wiper Cleaning"\(P. 132\)](#)

2.9 Auto Correction

The auto-correction function (DAS: Dot Adjustment System) detects a correction pattern with the sensor and automatically corrects the drop position.

- 1 On the LOCAL mode screen, select [ADJUST].

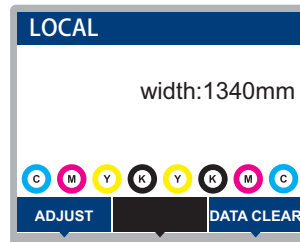

- 2 Select [Auto-correction], then press the [ENTER] key.



- 3 Select the items, then press the [ENTER] key.

- The following items be configured:
 - [All]: Automatically performs feed and dot position correction.
 - [Feed Comp.]: Automatically performs feed correction.
 - [Drop.PosCorrect]: Automatically performs dot position correction.



- Dot position correction can also be performed for each printing condition. In this Select [Media Setting] > [Auto-correction] > [Drop.PosCorrect] > [Printing conditions], then press the [ENTER] key.



- Check to confirm that the media does not lift up.
- Load white and clean media.
- Media such as synthetic paper, tarpaulin, or cloth media may not be detected.
- Do not send RIP data from the PC during pattern printing.
- If automatic correction is unsuccessful, correct the position manually. [MENU] > [Media Setting] > [Feed Comp.] or [Drop.PosCorrect]  "Feed Correction"(P. 71)  "Correcting the Drop Position"(P. 73)

2.10 Feed Correction

Changing the media may affect the feed amount due to various factors, including the weight and thickness of the media and whether the take-up unit is used. Correct the drop position to suit the type of media used. Image defects (e.g., dark or light streaks) will result if the feed is not properly corrected.

Check beforehand

- Is media loaded? 🖨️ "Loading the Media"(P. 50)
- **Does the heater temperature suit the media to be used?** 🖨️ "Setting the Heater Temperature"(P. 66)
- For roll media, is the rear roll media free of sagging?
- When using the take-up unit, is the media mounted on the paper core of the take-up unit? 🖨️ "Loading the Roll Media"(P. 55)

Feed Correction Procedure

Print a correction pattern, then enter the correction value. The value corrected here will also be updated on the Media Setting menu.



- When using the take-up unit, load media on the take-up unit before correcting.

- 1 On the LOCAL mode screen, select [ADJUST].

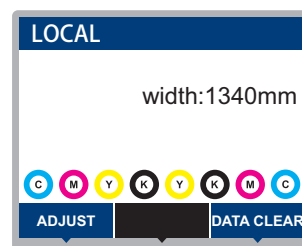

- 2 Select [Feed Comp.], then press the [ENTER] key.

- Correction pattern printing starts.

- 3 Check the print results.

- A correction value input screen appears.
- Adjust the bands so that the region between them is evenly colored.

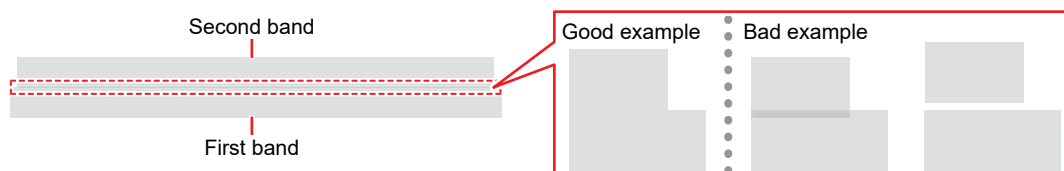

- 4 Enter the correction value, then press the [ENTER] key.

- "+" input: Increases the separation between bands.
- "-" input: Reduces the separation between bands.
- Increment the correction value by "30" to move the bands by approximately 0.1 mm.

- 5 Press the [ENTER] key.

- Print another correction pattern to check.



- Once adjustment is complete, the medium will be fed to the print origin. Sagging may occur in the rear roll medium. Rewind roll media by hand to eliminate any sagging.
-

Correcting the Media Feed During Printing

You can also correct the media feed amount in REMOTE mode or during printing.

- 1** Press [ADJUST] in REMOTE mode or during printing.
- 2** Enter the correction value, then press the [ENTER] key.
 - Correction value: -9999 to 9999
 - The value entered here will be updated immediately.

2.11 Correcting the Drop Position

Changing the media and print head height and temperature changes around the print head will also alter the drop positions. Correct the drop position to suit the type of media used. Image defects (e.g., overlaid lines or blurred images) will result if the drop position is not properly corrected.

Check beforehand

- Was the print head adjusted? 🖱️ ["Adjusting Print Head Height"\(P. 45\)](#)
- Is media loaded? 🖱️ ["Loading the Media"\(P. 50\)](#)
- **Does the heater temperature suit the media to be used?** 🖱️ ["Setting the Heater Temperature"\(P. 66\)](#)



- Load media at least 500 mm wide. You cannot print the entire pattern if media less than 500 mm wide is used.

Drop Position Correction Procedure

Print a correction pattern, then enter the correction value. The value corrected here will also be updated on the Media Setting menu. This must be adjusted for each print resolution.

- 1 On the LOCAL mode screen, select [ADJUST].

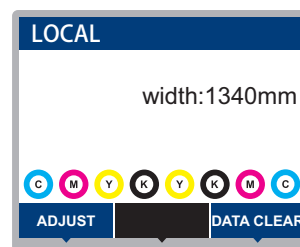

- 2 Select [Drop.PosCorrect], then press the [ENTER] key.

- 3 Select the resolution, then press the [ENTER] key.

- Select the resolution to be adjusted. When "All" is selected, correction patterns for all resolutions will be printed. 🖱️ ["Media Setting Menu"\(P. 110\)](#)



- The indicated resolutions are those in the scan direction.

- 4 Check the print results.

- A correction value input screen appears.
- Enter the position where the two upper and lower lines coincide.

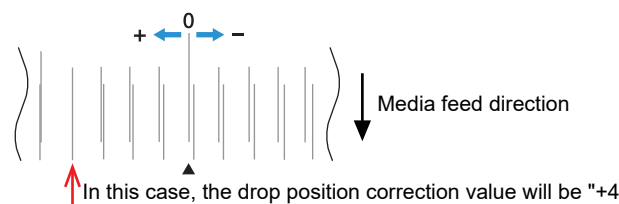

- 5 Enter the correction value, then press the [ENTER] key.

- Correction value: -40 to 40



- If the lines do not coincide when the correction value is within the range -40 to 40, the print head height may have been improperly adjusted. Adjust the print head height.
 ["Adjusting Print Head Height"\(P. 45\)](#)
-

6 Enter the correction value in the same way for pattern 2 and subsequent patterns.

2.12 Preparing RIP data

The explanation here applies to MIMAKI RIP software (RasterLink).



- Prepare suitable image data for printing.

1 Launch RasterLink.

- Click the icon on the PC desktop.



2 Select the image data to print.

- (1) Select [File] > [Open].
 - (2) Select the desired image data, then click [Open].
- If multiple printers are registered, select CJV200-160 from "Printer Name".

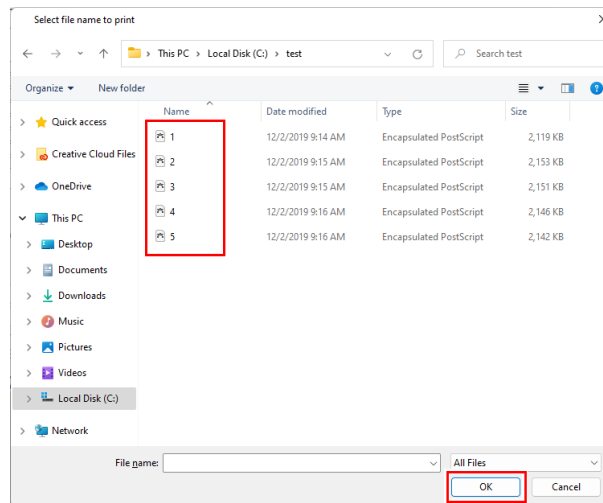

3 Select the image data imported.

- The image data is added in the tab for CJV200-160 selected in "Printer Name".

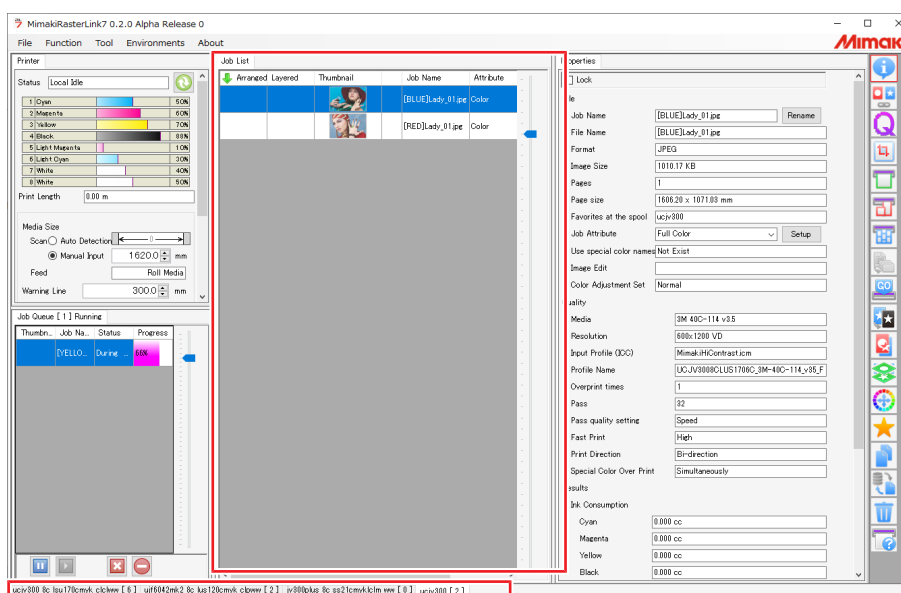

4 Edit the image.

- Specify the following settings by clicking the function icons shown on the right-hand side of the screen:

 (General Print): Specifies settings like enlargement/reduction and rotation.

 (Quality): Selects a color profile for the media and ink set loaded in this machine.



- For more information, refer to the RasterLink reference guide. <https://mimaki.com/download/software.html>
-

5 Print image data.

-  "Starting Printing"(P. 78)

(1) Click  (Execution) from the function icons on the right-hand side of the screen.

(2) Select "Immediate Print" or "RIP and Print", then click [Start].



- Media width must be reacquired after replacing media.

(1) Select the tab for, for example, CJV200-160 in the main window.

(2) Click  (Update the printer status) in the Printer tab.

2.13 Printing

Check beforehand

- Was the print head adjusted? 🖱️ ["Adjusting Print Head Height"\(P. 45\)](#)
- Were the pinch roller positions adjusted? 🖱️ ["Adjust the Pinch Roller Positions."\(P. 46\)](#)
- Is media loaded? 🖱️ ["Loading the Media"\(P. 50\)](#)
- Was the pinch roller pressure adjusted? 🖱️ ["Setting the Pressure and Number of Pinch Rollers to Use"\(P. 65\)](#)
- For roll media, is the rear roll media free of sagging?
- When using the take-up unit, was the media mounted on the paper core of the take-up unit? 🖱️ ["Loading the Roll Media"\(P. 55\)](#)



- Condensation may form on the print head nozzle surface depending on the ambient temperature and humidity. The formation of condensation may cause ejection failures (e.g., nozzle clogging or deflection). Perform head cleaning if any ejection failures (e.g., nozzle clogging or deflection) occur during printing. 🖱️ ["Head Cleaning"\(P. 69\)](#)
Set the platen heater to a temperature not exceeding 35 °C, and ensure that the ambient temperature is within the permissible operating temperature range (20 to 30 °C). 🖱️ ["Installation Precautions"\(P. 15\)](#)

Changing the origin

The print start position can be altered. Use the LED pointer to set the origin.

- Print origin default value
 - Feed (longitudinal, X') direction: Approx. 75 mm to rear from platen cutting slot
 - Scan (lateral, Y') direction: 15 mm from right edge of media

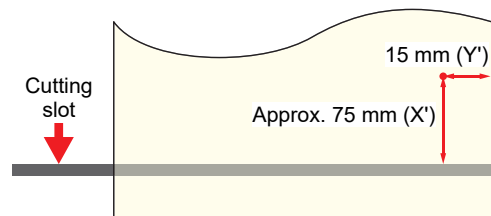

- 1 On the LOCAL mode screen, press ▲▼◀▶.**
 - The Origin Setup screen appears.
- 2 Press ▲▼◀▶ to move the origin to the desired position.**
 - The carriage moves left and right and feeds the medium.
- 3 Press the [ENTER] key.**
 - The origin is updated.

Starting Printing

1 Send the RIP data from the PC.

-  "Preparing RIP data"(P. 75)



- If the message "Attention20A Driver version" appears, install the latest Mimaki driver.
<https://mimaki.com/download/inkjet.html>

2 Start printing.

- Printing starts once RIP data is received.

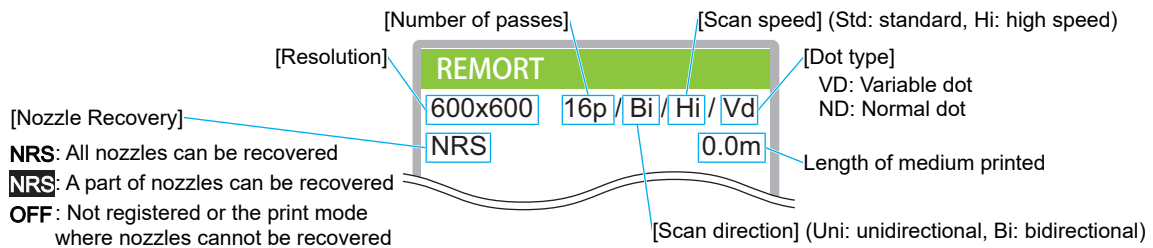

- Print speeds may differ for the same image data, depending on the width of the medium loaded, print origin position, and resolution.
- If an error occurs, the machine switches to LOCAL mode once printing is completed. Further printing is not possible.

Pausing Printing

1 Press [LOCAL] while printing is in progress.

- Printing is paused.
- If data is being sent from a PC, data transmission is paused at the PC.

2 Press [REMOTE].

- Printing resumes.



- No other functions can be used when printing is paused.

Stopping Printing (Data Clear)

- 1 On the LOCAL mode screen, select [DATA CLEAR].

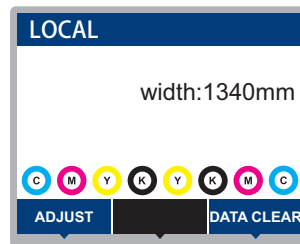

- 2 Press the [ENTER] key to clear the received data.
 - The receive buffer is cleared.

2.14 Cutting the media

- 1** On the LOCAL mode screen, press ▲▼◀▶.
 - The Origin Setup screen appears.
- 2** Press ▲▼ to feed the media to the position required for cutting.
- 3** Select [CUT].
- 4** Press the [ENTER] key.
 - The media is cut.

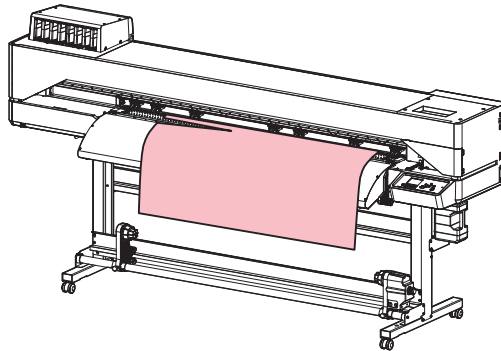

When the machine is not in use, raise the clamp lever to **separate the pinch rollers from the grit rollers**.

- Leaving the pinch rollers lowered may cause them to become deformed and prevent media from being fed correctly.
 - Leaving media loaded will subject it to force from the pinch rollers, which may leave pinch roller marks on it.
-

Chapter 3 Cutting



This chapter

This chapter describes cutting procedures and setting methods.

Cutting Process	82	Test Cutting	93
Installing Cutting Tools	84	Cutting the Cutting Data	94
Using the Cutter	84	Changing the origin	94
Using a Pen	88	Starting Cutting	94
Setting the Cutting Conditions	92	Stopping Cutting (Data Clear)	95
		Retracting the Cutter Unit	95

3.1 Cutting Process

1. Turn on the power.

 ["Turning On the Power"\(P. 31\)](#)

2. Connect this machine to the PC on which the cutting software is installed.

 ["Using a USB Cable"\(P. 34\)](#)

 ["Using a LAN Cable"\(P. 33\)](#)

3. Adjust the Pinch Roller Positions.

Adjust the pinch roller positions to suit the width of the set media. Adjust the pinch roller positions so that the pinch rollers are positioned above the grit rollers. The pinch rollers at both ends should be aligned to within 10 cm from the left edges and 2 cm from the right edges of the media.  ["Adjust the Pinch Roller Positions."\(P. 46\)](#)

4. Loading the Media

This machine can be used with roll media and leaf media.  ["Loading the Media"\(P. 50\)](#)

5. Adjust the number and pressure of pinch rollers to use.

Set an appropriate pressure for the set media.  ["Setting the Pressure and Number of Pinch Rollers to Use"\(P. 65\)](#)

6. Installing Cutting Tools

This machine can be used with a cutter and a pen (ballpoint pen).  ["Installing Cutting Tools"\(P. 84\)](#)

7. Set the cutting speed and pressure.

Set the cutting speed and pressure to match the type of media and tools in use.  ["Setting the Cutting Conditions"\(P. 92\)](#)

8. Perform test cutting.

Perform a test cut to confirm that the tool conditions are set appropriately.  ["Test Cutting"\(P. 93\)](#)

9. Cutting the Cutting Data

👉 "Cutting the Cutting Data"(P. 94)

10. Cutting the media

👉 "Cutting the media"(P. 80)

3.2 Installing Cutting Tools

This machine can be used with the following tools:

- Cutter (for cutting media)
Used to cut the printed image on media or to cut characters with the cutting sheet. 🖱️ ["Using the Cutter"\(P. 84\)](#)
- Pen (ballpoint pen)
Used to adjust register marks This machine can be used with a ballpoint pen or cartridge refill. 🖱️ ["Using a Pen"\(P. 88\)](#)

Using the Cutter

Installing the Cutter in the Cutter Holder

Be careful to keep the cutter from falling into a gap in this machine. We recommend replacing the cutter on the media so you can easily pick up the cutter blade if it falls.



- Avoid touching the cutter blade. Failure to do so may result in injury.
- Do not shake the cutter holder. The cutter blade may come out.

1 Remove the cap from the cutter holder.

- Turn in the direction indicated by the arrow in the picture.

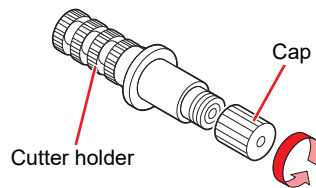

2 Insert the cutter into the cutter holder.

- Use tweezers to insert the cutter.

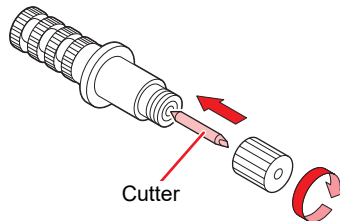

3 Fix the cap by turning in the direction indicated by the arrow in the picture.

Adjusting the Cutting Blade Protrusion Length

Adjust the cutting blade protrusion length (0.2 to 0.5 mm).

- If the base paper is thicker than the label film: $(\text{label film thickness} + \text{base paper thickness})/2$

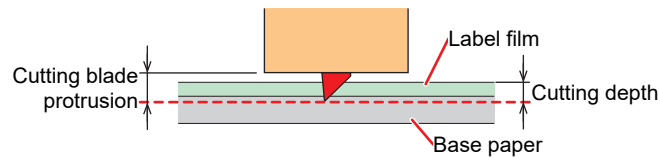

- If the base paper is thinner than the label film: As far as to cut into label film

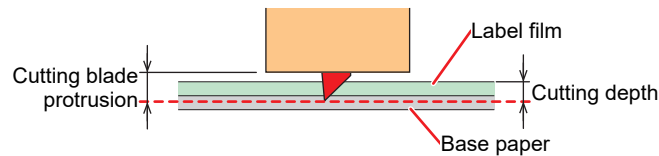

- An option is available to accurately adjust the protrusion amount of the blade tip.
Part number: OPT-C0066 "blade adjuster (for eccentric cutter)"

1 Turn the adjusting knob to adjust the protrusion of the cutting blade.

- Turn the adjusting knob in the direction indicated by the arrow in the picture to have the blade protrude. (0.5 mm per turn)

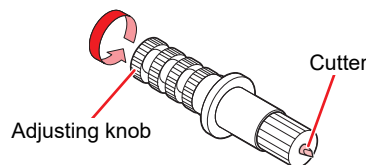

2 Check the cutting performance.

- Adjust the pressure so that it leaves slight marks on the base paper. A cutting blade that protrudes too far may damage the machine. [☞ "Setting the Cutting Conditions"\(P. 92\)](#) [☞ "Test Cutting"\(P. 93\)](#)



- When using the cutter holder included in the delivery, you can adjust the protrusion length while the cutter is attached to the tool holder. (0.5 mm per turn of the adjusting knob)

Installing the Cutter Holder

- 1** On the LOCAL mode screen, select [MENU] > [Cutting], then press the [ENTER] key.
 - The Cutting menu is displayed.
- 2** Select [Tool Change], then press the [ENTER] key.
- 3** Open the maintenance cover (right side).



- The cutter unit can be moved manually. Move the carriage slowly to a position allowing easy access while working.

- 4** Turn the knob screw and loosen the holder presser.

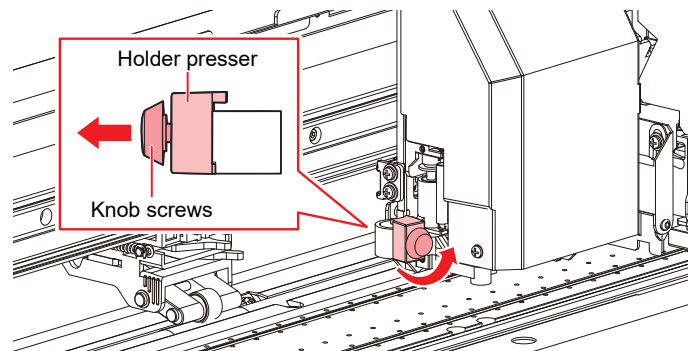

- 5** Insert the cutter holder into the tool holder.

- Push the brim of the cutter holder against the holder presser.

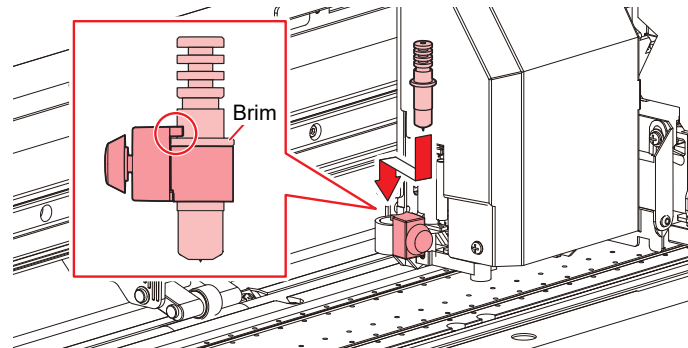

- 6** Secure the cutter holder.

- Turn the knob screw to secure the holder presser. Failure to secure firmly may result in lower quality.

- 7** Close the maintenance cover (right side), then press the [ENTER] key.

Using the Included Cutter Holder (SPA-0001)

1 Loosen the lock nut of the cutter holder and extract the adjusting knob.

- Turn in the direction indicated by the arrow in the picture.

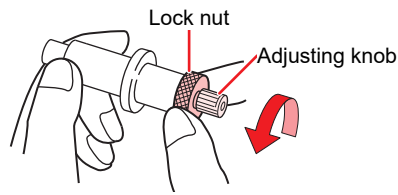

2 Insert the cutter into the adjusting knob.

- Use tweezers to insert the cutter.

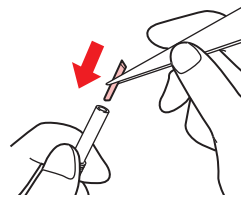

3 Fix the lock nut by turning in the direction indicated by the arrow in the picture.

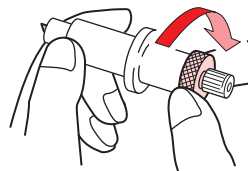

Adjusting the Cutting Blade Protrusion Length

1 Loosen the lock nut of the cutter holder.

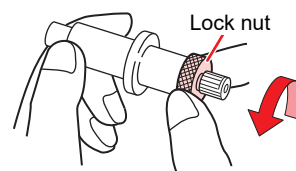

2 Turn the adjusting knob to adjust the protrusion of the cutting blade.

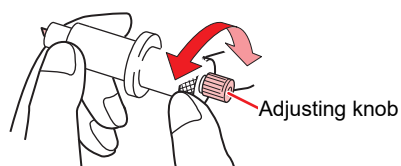

3 Fix the lock nut by turning in the direction indicated by the arrow in the picture.

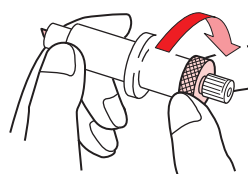

Using a Pen

Installing a Refill Cartridge for a Ballpoint Pen in the Pen Holder

The image quality can vary depending on the type of refill cartridge. Recommended: SXR-5 (Mitsubishi Pencil Co., Ltd.)

1 Remove the cap from the pen holder.

- Turn in the direction indicated by the arrow in the picture.

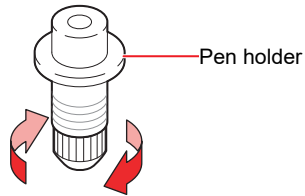

2 Insert a refill cartridge into the pen holder.

- Insert the refill cartridge until it hits the pen holder.

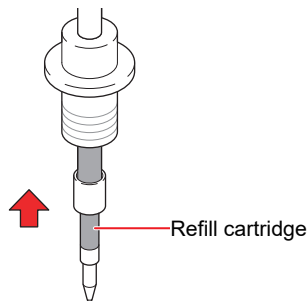

3 Insert the spring into the refill cartridge.

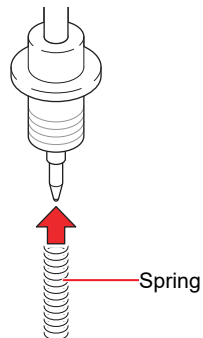

4 Fix the cap by turning in the direction indicated by the arrow in the picture.

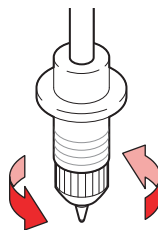

Installing a Ballpoint Pen in the Pen Adapter

Use a ballpoint pen with a diameter of 8 to 9 mm. The ballpoint pen type may affect image quality.
Recommended: K105-GA (Pentel Co., Ltd.)



- Do not use ballpoint pens as shown below. Some types of ballpoint pens may tilt.



Pens with shafts that change thickness midway

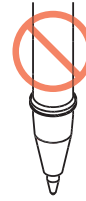

Pens with protrusions or bumps on the shaft

1 Put the cap on the pen adapter.

- The cap is used to adjust the height of the pen nib.

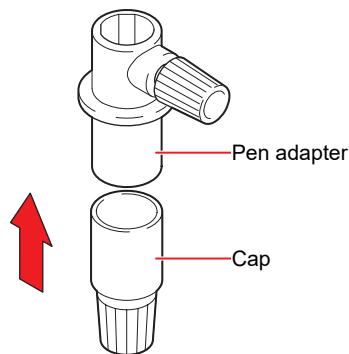

2 Insert the ballpoint pen into the pen adapter.

- Insert the pen nib until it hits the cap.

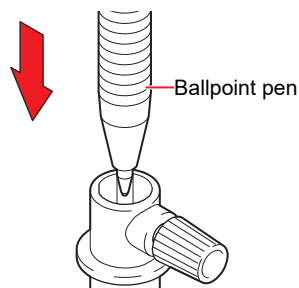

3 Fix the pen nib by turning the knob screw in the direction indicated by the arrow in the picture.

- Be careful to avoid overtightening the knob screw. Disregarding this precaution may damage or break the ballpoint pen.

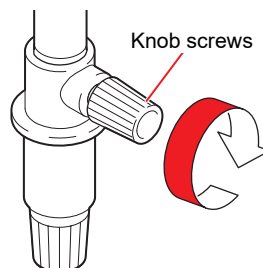

4 Remove the cap.

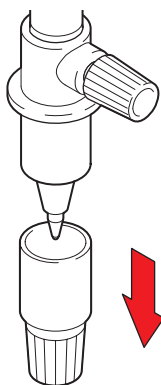

Installing a Pen

1 On the LOCAL mode screen, select [MENU] > [Cutting], then press the [ENTER] key.

- The Cutting menu is displayed.

2 Select [Tool Change], then press the [ENTER] key.

3 Open the maintenance cover (right side).



- The cutter unit can be moved manually. Move the carriage slowly to a position allowing easy access while working.

4 Turn the knob screw and loosen the holder presser.

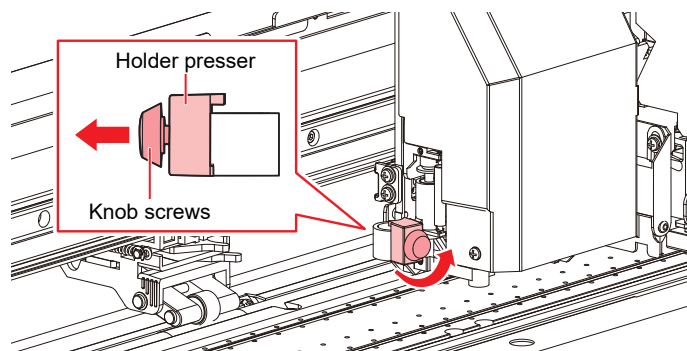

5 Insert the pen holder or pen adapter into the tool holder.

- Push the brim of the pen holder or pen adapter against the holder presser.

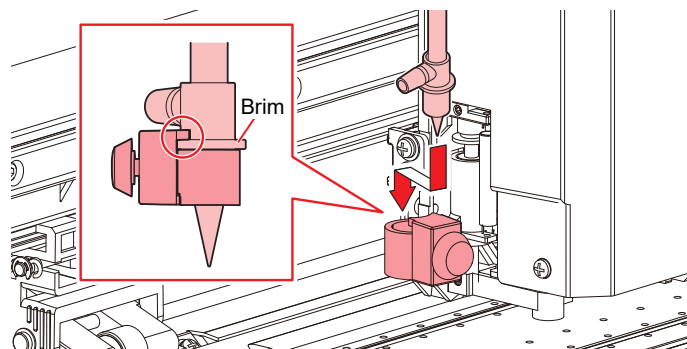

6 Secure the pen holder or pen adapter.

- Turn the knob screw to secure the holder presser. Failure to secure firmly may result in lower quality.

7 Close the maintenance cover (right side), then press the [ENTER] key.

3.3 Setting the Cutting Conditions

You can set the cutting speed and pressure to match the type of media and tools in use.

- 1 On the LOCAL mode screen, select [TOOL].

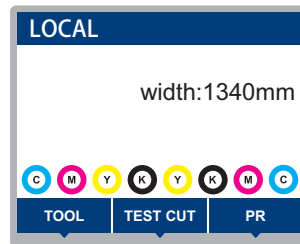

- 2 Set the conditions.

- The following items can be configured:
- The settings are retained even when the power is turned off.

Item	Setting	Overview
TOOL	CUT1 to 7/ PEN	<ul style="list-style-type: none"> • Press the key repeatedly to change the tool condition in the sequence shown below.
Speed	1 to 30 cm/s	<ul style="list-style-type: none"> • Sets the speed for cutting or pen writing.
Pressure	CUT: 10 to 450 g PEN: 10 to 150 g	<ul style="list-style-type: none"> • Sets the pressure for cutting or pen writing. • This setting is also required for half cuts.
Offset ^{*1}	0.00 to 2.50 mm	<ul style="list-style-type: none"> • Sets the length from the center of the cutter holder to the cutting blade.
Half Cut ^{*1}	ON/OFF	<ul style="list-style-type: none"> • Cuts across a dotted line without cutting out the base paper. <ul style="list-style-type: none"> • If Half Cut is set to "ON", the three items listed below are displayed: Set the following three items and pressure in the Cutting Conditions menu:
Half Cut Pressure	0 to 300 g	<ul style="list-style-type: none"> • Sets the pressure for the uncut portion.
H-Leng	0.1 to 5.0 mm	<ul style="list-style-type: none"> • Sets the uncut length.
C-Leng	5 to 150 mm	<ul style="list-style-type: none"> • Sets the cut length.

*1. This cannot be set when PEN is selected.

3.4 Test Cutting

Execute test cutting to confirm that the tool conditions are set appropriately.

Increase pressure as the cutter blade grows dull with wear. This is only a temporary measure. We recommend replacing the cutter blade to maintain cutting quality.

- 1 On the LOCAL mode screen, select [TEST CUT].

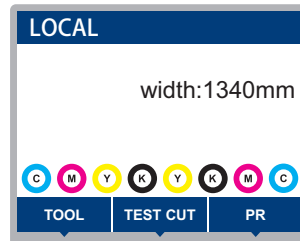

- 2 Select [Test Cut], then press the [ENTER] key.

- Test cutting starts.

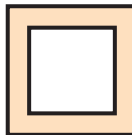





- Check the test cut results, and change the cutting conditions accordingly.

Symptom	Cause	Solution
An uncut section was identified.	<ul style="list-style-type: none"> • Because the speed is too high, the cutting blade passed over the media. 	<ul style="list-style-type: none"> • Reduce the [Speed]. "Setting the Cutting Conditions"(P. 92) • Tighten the knob on the tool holder. "Installing the Cutter Holder"(P. 86)
The base paper of the media is cut.	<ul style="list-style-type: none"> • The pressure is excessive. • The cutting blade protrudes too far. 	<ul style="list-style-type: none"> • Reduce the [Pressure]. "Setting the Cutting Conditions"(P. 92) • Reduce the protrusion of the cutting blade. "Adjusting the Cutting Blade Protrusion Length"(P. 85)
The corners are rounded.	<ul style="list-style-type: none"> • The length from the center of the cutter holder to the cutting blade is not set correctly. 	<ul style="list-style-type: none"> • Adjust the [Offset] value according to the cutter used. "Setting the Cutting Conditions"(P. 92)
The corners are turned up.	Two or more of the following apply: <ul style="list-style-type: none"> • The cutting blade protrudes too far. • The pressure is excessive. • The [MENU] > [Cutting] > [Setup Sub Menu] > [Adj-prs Offset] value is large. 	<ul style="list-style-type: none"> • Reduce the protrusion of the cutting blade. "Adjusting the Cutting Blade Protrusion Length"(P. 85) • Reduce the [Pressure]. "Setting the Cutting Conditions"(P. 92) • Reduce the [Adj-prs Offset] value. "Cutting Menu"(P. 122)

3.5 Cutting the Cutting Data

Check beforehand







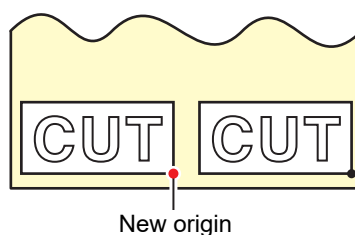

- Was the head height adjusted?  "Adjusting Print Head Height"(P. 45)
- Were the pinch roller positions adjusted?  "Adjust the Pinch Roller Positions."(P. 46)
- Is media loaded?  "Loading the Media"(P. 50)
- Are the pinch rollers configured?  "Setting the Pressure and Number of Pinch Rollers to Use"(P. 65)

Changing the origin

You can change the cutting start position. Use the LED pointer to set the origin. The origin set here will be the origin of the cutting software you are using.

When cutting the same data again, change the origin. If not, cutting starts at the same position.



- 1 On the LOCAL mode screen, press    .**
 - The Origin Setup screen appears.
- 2 Press     to move the origin to the desired position.**
 - The carriage moves left and right and feeds the medium.
- 3 Press the [ENTER] key.**
 - The origin is updated.
 - The set tool conditions are displayed on the display.

Starting Cutting

- 1 Press [REMOTE].**
 - The machine switches to REMOTE mode and is ready for cutting.
- 2 Send the cutting data from the PC.**



- For more information, refer to the operation manual of the cutting software you are using.

- 3 Cutting starts.**
 - Cutting starts once the cutting data is received.
 - The remaining amount of data is displayed on the display.



- If the media moves out of place during cutting, immediately turn off the power. Continuing to cut while the media is not in place may damage the machine.

Pausing Cutting

- 1 Press [LOCAL] while cutting is in progress.
 - Cutting is paused.
 - If data is being sent from a PC, data transmission is paused at the PC.

- 2 Press [REMOTE].

- Cutting resumes.



- No other functions can be executed while printing is paused.

Stopping Cutting (Data Clear)

- 1 On the LOCAL mode screen, select [DATA CLEAR].

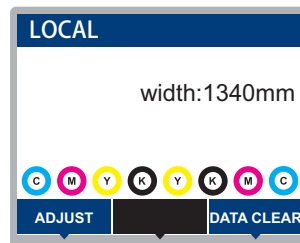

- 2 Press the [ENTER] key to clear the received data.

- The receive buffer is not cleared.

Retracting the Cutter Unit

When cutting or printing-with-a-pen is completed, the cutter unit is positioned on the platen. To check the cutting result or to set new media, retract the cutter unit from the platen.

- 1 On the LOCAL mode screen, select [TEST CUT].

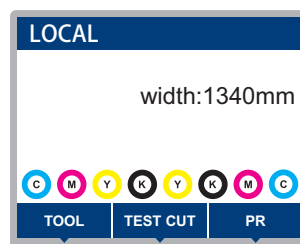

- 2 Select [Cut Head Move/Retract], then press the [ENTER] key.

- If the cutter unit is not connected to the carriage, it moves to the station to connect to the carriage.



- If the cutter unit is connected to the carriage, detach the carriage and move it to the maintenance space on the left side.

Chapter 4 Cutting Data with Register Marks



This chapter

This chapter describes the register mark creation conditions and basic information.

Process for Cutting Data with Register Marks	98	Setting Mark Detection Conditions	106
Creating Register Marks	100	Detecting the Position of the Register Mark	
Register Marks	100	Origin	107
Register Mark Size	101	ID Cut Process	108
Spacing Between Register Marks	102		
Reading Range of Register Marks	103		
No-Plotting Areas Around Register Marks	104		
Combined Operations of Printing and Cutting	105		

4.1 Process for Cutting Data with Register Marks

1. Create data with register marks.

 ["Creating Register Marks"\(P. 100\)](#)

This machine can detect the following three types of register marks:

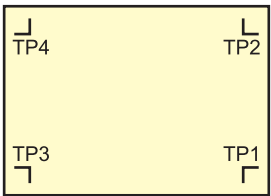
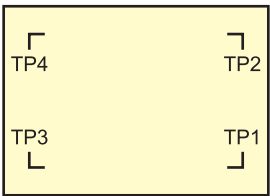
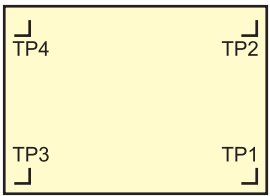
Type 1	Type 2	Zero margin register mark
		

2. Print printing data with register marks.

 ["Print Process"\(P. 42\)](#)

3. Prepare for cutting.

 ["Cutting Process"\(P. 82\)](#) (Steps 4 to 8)

4. Register the information for the printed register marks.

 ["Setting Mark Detection Conditions"\(P. 106\)](#)

5. Detect the register mark origin.

 ["Detecting the Position of the Register Mark Origin"\(P. 107\)](#)

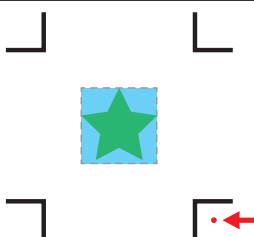
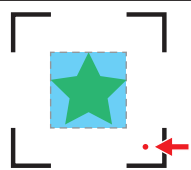
(Mark shape) Type 1	(Mark shape) Type 2
	

6. Cut the data.

 ["Cutting the Cutting Data"\(P. 94\)](#)

7. Cutting the media

 ["Cutting the media"\(P. 80\)](#)

4.2 Creating Register Marks

Printing image data with "register marks" can increase cutting accuracy and quality. There are some limitations to register marks. Read the following thoroughly before creating register marks.



- Trimming register marks cannot be used with the machine.

Register Marks

The following three types of register marks can be used with this machine:

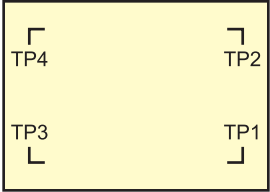
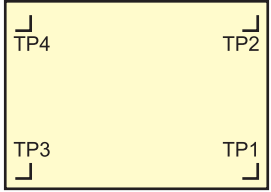
Type 1	Type 2	Zero margin register mark
		



- Use mark 4 (TP4) to perform trapezoidal corrections. Mark 4 can be skipped, but doing so will reduce cutting accuracy.
Trapezoidal correction: Corrects the difference between the right and left feed amount of the media.

● How cutting accuracy varies by speed

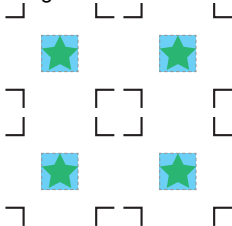
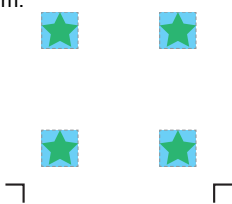
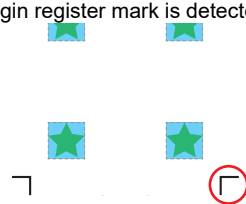
Accuracy	Speed	Register Mark Layout	Detection Type
Higher ↑	Slower ↑	Register marks are arranged at the four corners of each item of image data. 	All register marks are detected.
↓ Lower	↓ Faster	Register marks are arranged at the four corners of the image data as a whole and at positions between them. 	All register marks are detected (4 marks). Only the origin register mark is detected (1 mark). 
		No register marks	No register marks

Media and Register Mark Color

We recommend using white media and black register marks. The machine may fail to detect register marks in other colors.

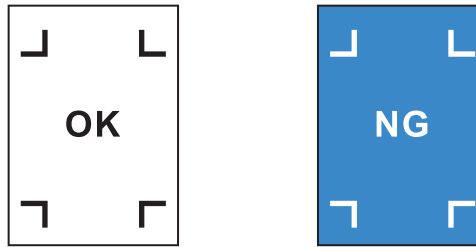

Blurred Register Marks

Ensure that printed register marks are not blurred. If the register marks are blurred, the mark origins may be incorrectly identified, or the machine may fail to detect the register marks.



Register Mark Size

The recommended register mark size (A) is within the range of A4 size (210 mm × 297 mm) to A3 size (297 mm × 420 mm). If the dimensions exceed A3, the machine may fail to detect register marks due to media feeding problems (e.g., media meandering).

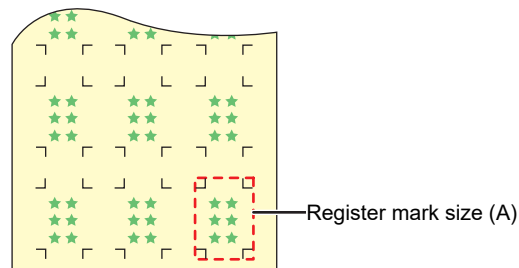

Standards for Register Mark Length and Line Width

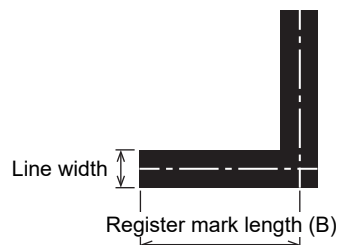

The recommended register mark length and line width are as shown below. The machine may fail to detect register marks that lie outside the recommended range.

Register mark size (A)	Register mark length (B)	Line width
200 mm or less	5 mm	0.5 mm
201 to 500 mm	8 mm	

Register mark size (A)	Register mark length (B)	Line width
501 to 1,000 mm	15 mm	1.0 mm
1,001 to 2,000 mm	25 mm	
2,001 mm or more	35 mm	

- If the "Fill around the registration marks" function of the RIP software is enabled, the register mark length (B) should be 10 mm or more.

When Printing Register Marks Continuously

The register mark length (B) should be 8 mm or more. The machine may fail to detect register marks less than 8 mm if it reads them continuously.

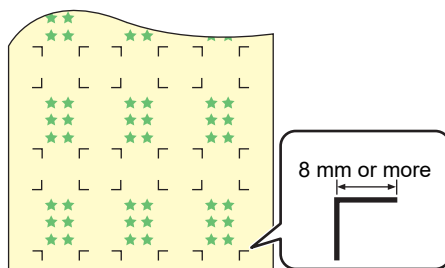

Spacing Between Register Marks

The spacing between register marks (C) is as shown below.

(Mark shape) Type 1	(Mark shape) Type 2
Register mark length (B) x 2 + α, up to 1,000 mm	Register mark length (B) + α, up to 1,000 mm

● Mark Origin Mis-detection Example

- If the spacing between register marks (C) is narrow, as shown in the figure below, the machine may fail to detect them.

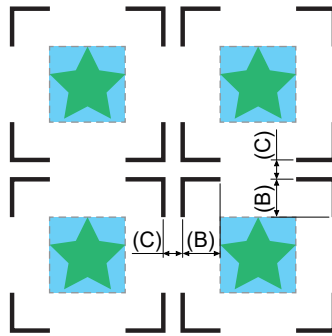

Reading Range of Register Marks

This machine can detect register marks in the range shown below. If the margin is small, the edge of the media may be incorrectly identified as a register mark.

When copying data with MIMAKI RIP software (RasterLink), leave a space of at least 210 mm from the rear edge of the media.

(Mark shape) Type 1	(Mark shape) Type 2
<p>110 (or 210) mm</p> <p>50 to 3,000 mm</p> <p>50 mm or more</p> <p>20 mm or more</p> <p>5 mm or more</p> <p>5 mm or more</p> <p>[Rear]</p> <p>[Front]</p> <p>■ : No-plotting area</p> <p>■ : Cut area</p> <p>■ : Media</p>	<p>110 (or 210) mm + (Register mark length (B)/2) or more</p> <p>50 mm or more</p> <p>50 mm or more</p> <p>20 mm + (Register mark length (B)/2) or more</p> <p>5 mm or more</p> <p>5 mm or more</p> <p>[Rear]</p> <p>[Front]</p> <p>■ : No-plotting area</p> <p>■ : Cut area</p> <p>■ : Media</p> <p>Within 3,000 mm</p>

ID Cut

This machine can detect register marks in the range shown below. If the margin is small, the edge of the media may be incorrectly identified as a register mark.

When copying data with MIMAKI RIP software (RasterLink), leave a space of at least 210 mm from the rear edge of the media.

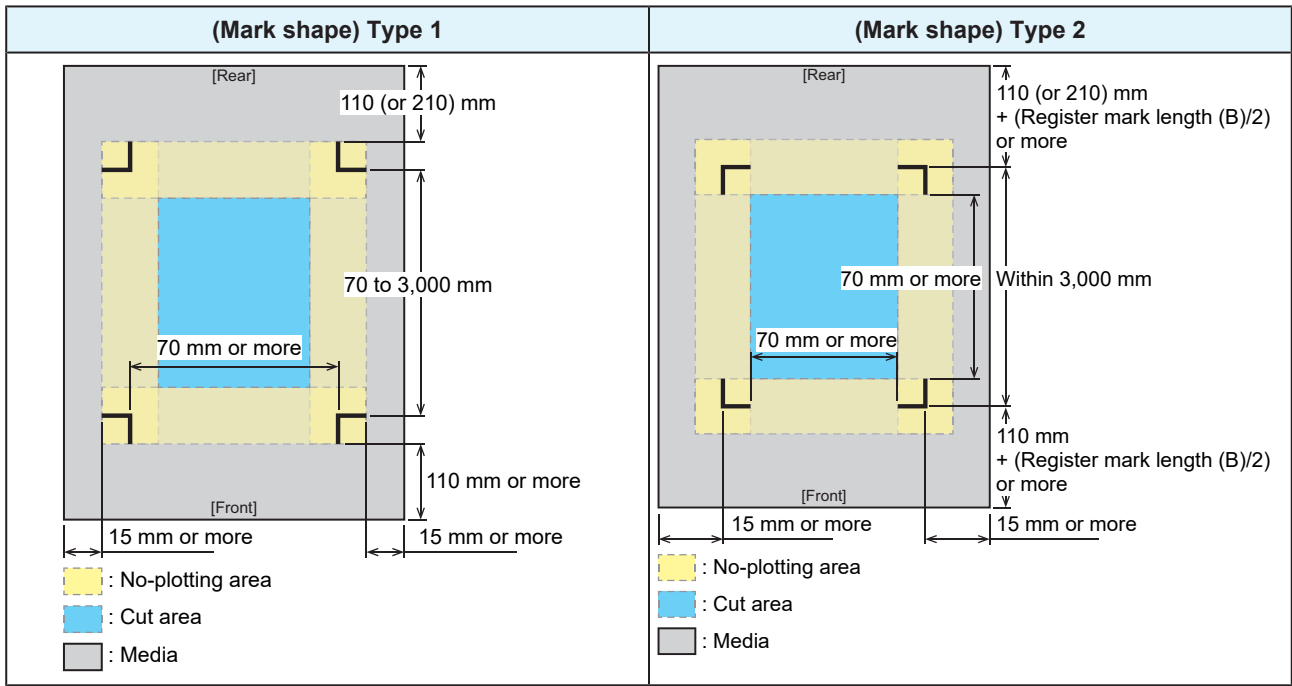

• For more information, refer to the ID Cut Guide. <https://mimaki.com/download/software.html>

No-Plotting Areas Around Register Marks

Do not plot data around register marks. The mark origins may be identified incorrectly, or the machine may fail to detect the register marks.

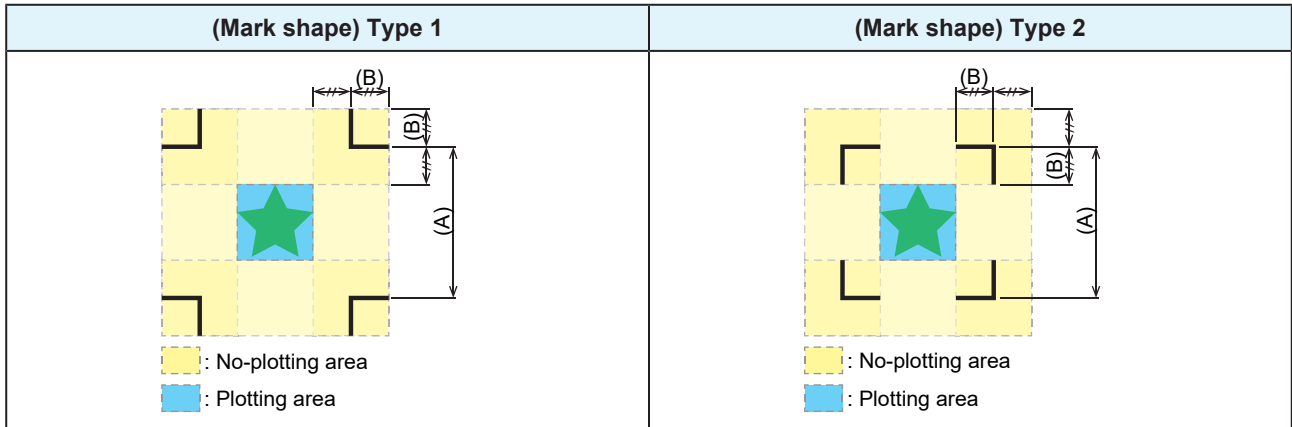

● Mark Origin Mis-detection Example

- If register marks are plotted in the no-plotting area as shown in the figure below, the line may be incorrectly identified as a register mark.

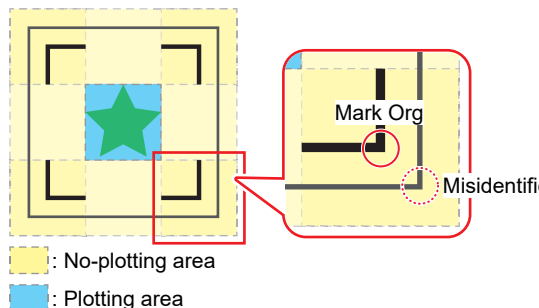

Combined Operations of Printing and Cutting

When printing and cutting with MIMAKI software (RasterLink, FineCut), please note the following:

- The mark size and mark shape settings configured in the machine will be disregarded. Software settings take precedence.
- We recommend printing and cutting using data with register marks. The volume of print data may affect cutting accuracy.
- Although it is possible to print and cut data without register marks using take-up units, doing so may reduce cutting accuracy.

4.3 Setting Mark Detection Conditions

Set the conditions of the printed register marks.

1 On the LOCAL mode screen, select [MENU] > [Cutting], then press the [ENTER] key.

- The Cutting menu is displayed.

2 Select [Mark Detect], then press the [ENTER] key.

- The Mark Detect menu is displayed.



- The Mark Detect menu can also be displayed as follows:

- (1) On the LOCAL mode screen, select [TEST CUT].
 - (2) Select [TP Detect Setup], then press the [ENTER] key.
-

3 Select and set the items.

-  ["Cutting Menu"\(P. 122\)](#)

4.4 Detecting the Position of the Register Mark Origin

- 1 On the LOCAL mode screen, select [TEST CUT].

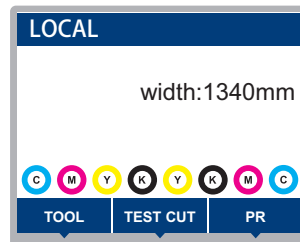

- 2 Select [Mark Detection], then press the [ENTER] key.

- The machine switches to MARK DETECT mode.
- The cutting unit moves over the platen.



- If the machine does not switch to MARK DETECT mode, set the [TEST CUT] > [TP Detect Setup] > [Detect] setting to "ON".

- 3 Press to move the LED pointer to the center of the register mark.

(Mark shape) Type 1	(Mark shape) Type 2

- 4 Press the [ENTER] key.

- Register mark detection starts.

4.5 ID Cut Process

1. Create data with ID Cut.



- For more information, refer to the ID Cut Guide. <https://mimaki.com/download/software.html>

2. Print printing data with ID Cut.

 "Print Process"(P. 42)

3. Prepare for cutting.

 "Cutting Process"(P. 82) (Steps 4 to 8)

4. Register the information for the printed register marks.

 "Setting Mark Detection Conditions"(P. 106)

5. Detect the register mark origin.

 "Detecting the Position of the Register Mark Origin"(P. 107)

6. Cut the data.

 "Cutting the Cutting Data"(P. 94)

7. Cutting the media

 "Cutting the media"(P. 80)

Chapter 5 Setup



This chapter

This chapter describes the [MENU] functions.

Media Setting Menu	110	Environment Setting Menu	119
Maintenance Menu	113	Machine Status Menu	121
Registering Nozzle Recovery Manually ...	115	Cutting Menu	122
Nozzle Check (Option)	116	Copying the Last Data	124
Function Setting Menu	117	Preventing Uncut Media	125

5.1 Media Setting Menu

When you use the machine for the first time, the Select Use Media screen is displayed. Registering the Media The media Information and correction value can be saved in advance for specific media.

The user can select to prioritize the settings on the machine or the settings on the PC. Setting individual menus to "Host" prioritizes PC settings. To prioritize settings for this machine, select a setting other than "Host".



- For more information on how to specify RIP software, refer to the RIP software operating manual.

● Menu List

Item	Setting		Details
	*1	*2	
Feed Comp.	-9999 to <u>0</u> to 9999	-	Corrects the media feed amount. Print a pattern and enter the correction amount. "Feed Correction"(P. 71)
Drop.PosCorrect	-	-	Corrects the drop position for bi-directional printing. "Correcting the Drop Position"(P. 73)
(Resolution)	*	-	Select the resolution to be corrected. When "All" is selected, correction patterns will be printed for all resolutions. * The available resolutions vary according to the model.
(Correction Value)	-40.0 to <u>0</u> to 40.0	-	Check the pattern and enter correction values.
Auto-correction	-	-	The auto-correction function (DAS: Dot Adjustment System) detects a correction pattern with the sensor and automatically corrects the drop position.
All	-	-	When "All" is selected, "Feed Comp." and "Drop.PosCorrect" are corrected.
Feed Comp.	-	-	When "All" is selected, "Feed Comp." and "Drop.PosCorrect" are corrected.
Drop.PosCorrect	-	-	<ul style="list-style-type: none"> • Check to confirm that the media does not lift up. • Load white and clean media. • Media such as synthetic paper, tarpaulin, or cloth media may not be detected. • Do not send RIP data from the PC during pattern printing. • If automatic correction is unsuccessful, correct the position manually. [MENU] > [Media Setting] > [Feed Comp.] or [Drop.PosCorrect]
(Resolution)	*	-	Select the resolution to be corrected. When "All" is selected, correction patterns will be printed for all resolutions, and the drop position is corrected automatically. * The available resolutions vary according to the model.
MAPS4 *	-	-	MAPS4: Mimaki Advanced Pass System This function disperses the boundaries between passes to make feed streaks between passes less visible. Altering MAPS4 may alter the color. This function may be less effective with certain types of images.
MAPS4 *	AUTO/ MANUAL	-	This should normally be set to "AUTO". When set to "MANUAL", the following items are displayed:

Item		Setting		Details
		*1	*2	
	Speed	50 to 100 %	-	Reducing speed will make streaks less visible. However, printing will be slower.
	Smoothing Level (Color)	0 to 100 %	-	Increasing smoothing makes streaks less visible. Make separate settings for color and spot color (white).
	Smoothing Level (Spot)			
Heater		-	-	Set the heater temperature.  "Setting the Heater Temperature"(P. 66)
	PRE	OFF /20 to 60 °C	-	Preheats the media before printing to suppress rapid temperature change.
	PRINT	OFF /20 to 50 °C	-	Helps prevent ink bleeding.
	POST	OFF /20 to 60 °C	-	Allows ink to dry after printing.
	OFF time	None / 0 to 90 min	-	Sets the time before turning the heater off after printing.
Media Information		-	-	Enter the media information.
	Media Type	-	-	Select the media type to be used. The available media types vary depending on the model.
	Media Width	-	-	Sets the media width detection method.
	Detection Type	AUTO / MANUAL		<ul style="list-style-type: none"> AUTO: The media width is automatically detected with the sensor. MANUAL: ◀ Press ▶ to set the media width manually. <ul style="list-style-type: none"> When media width cannot be detected correctly, set the media width detection method to "MANUAL".
	Media Operation Form	Roll /Leaf	-	Select whether roll media or leaf media is used.
	Media Remain	-	-	The remaining roll media amount can be displayed and printed out in REMOTE mode. The print length will be displayed when leaf media is in use.
	Media Remain Manage	ON / OFF	-	<ul style="list-style-type: none"> ON: An input screen appears once the media width is detected. ▲ Press ▼ to set the media length. Press the [FUNC3] key on the "Origin Setup" screen to print the date and remaining media amount. OFF: The remaining media amount is not displayed.
	Length	0 to 500 m	-	Enter the roll media length.
Detail Setting		-	-	This is used to set various functions.
	Vacuum Fan	Host /Weak/ Standard/ Strong	Strong	<p>Sets the force with which the medium is held down.</p> <ul style="list-style-type: none"> This can be used to prevent media jamming and print head damage caused by the media lifting up.
	Continuous Running	ON/OFF		<ul style="list-style-type: none"> ON: The media is constantly held down under vacuum. OFF: The media is held down by vacuum only when required, such as during printing and feeding.
	Feed Speed	Host /10 to 100 to 200 %	100	<p>Sets the media feed speed.</p> <ul style="list-style-type: none"> Depending on print conditions, the speed may not vary for certain settings.

Item	Setting		Details
	*1	*2	
			<ul style="list-style-type: none"> Setting to 100 % or more reduces the time required to complete printing but may affect print quality due to insufficient drying time.
Media Name Change	-	-	You can change the name of a setting type. The name can include alphanumeric characters or symbols.
Delete MediaInfo	-	-	Delete the set media information.

*1. The default settings are shown underlined.



*2. Settings applied if no settings can be made in the RIP software (host) or if this machine is prioritized.



5.2 Maintenance Menu

This menu is used for maintenance actions. It also lets the user perform nozzle recovery if nozzle clogging persists even after cleaning and nozzle washing.

● Menu List

Item	Setting ^{*1}	Details
Station Maint.	-	This moves the carriage to allow station and print head maintenance.
Carriage Out	-	
Move To Platen Right End	-	Cleans around the station, including the cap, wiper, and NCU. ☞ "Cap Rubber Cleaning"(P. 130) ☞ "Cleaning the NCU (Option)"(P. 134)
Move To Maint. Space	-	Cleans around the print head. ☞ "Carriage Underside Cleaning"(P. 131) ☞ "Media Sensor Cleaning"(P. 137) ☞ "DAS (Automatic Correction Function) Sensor Cleaning"(P. 135)
Head height switching	-	Adjusts the height of the print head according to the thickness of the media. ☞ "Adjusting Print Head Height"(P. 45)
Nozzle Wash	1 to 99 min	Washes the print head nozzle surface with maintenance liquid to resolve ejection failures (e.g., nozzle clogging or deflection). ☞ "Print Head Nozzle Washing"(P. 161)
Pump Tube Cleaning	OFF / 1 to 168 h	Sets the interval for washing the suction pump tube (below the cap). ☞ "Ink Discharge Channel Cleaning"(P. 136)
Custody Wash	1 to 99 min	Perform this step if the machine will not be used for extended periods. The function washes nozzles and drainage channels to maintain the machine in optimal condition. ☞ "When this Printer is Left Unused for a Long Time"(P. 140)
Replace Wiper	-	Use this function when replacing the wiper. Replacing the wiper resets the wiper usage counter. ☞ "Wiper Replacement"(P. 144)
Cap Replacement	-	Use this function when replacing the cap. Replacing the cap resets the cap usage time stored in the machine. ☞ "Cap Replacement"(P. 145)
Test Printing	-	Print a test pattern to confirm that the ink prints correctly. Perform head cleaning if you observe any ejection failures (e.g., nozzle clogging or deflection). ☞ "Test Printing"(P. 67)
Cleaning	-	Several head cleaning methods are available. Choose the head cleaning method based on test print results. ☞ "Head Cleaning"(P. 69)
Nozzle Recovery	-	Allows other nozzles to be used for printing if maintenance actions like nozzle washing fail to resolve print defects (e.g., nozzle clogging, deflection).
Print	-	Prints a pattern to check nozzle condition and register the nozzle. ☞ "Registering Nozzle Recovery Manually"(P. 115)
Entry	-	Registers the nozzle without printing a pattern.
Reset	-	Initializes the details set.
Test Printing	ON/OFF	Sets whether to perform nozzle recovery before test printing.
Nozzle Check (Option)	-	☞ "Nozzle Check (Option)"(P. 116)

Item	Setting *1	Details
Printing Check	ON/ OFF	Performs nozzle clogging detection before printing starts.
Check Interval	-	Sets the nozzle clogging detection timing.
Length	0.1 to 30.0 to 100.0 m	Performs nozzle clogging detection after the length set is reached and before the next print starts.
File	1 to 30 to 1,000 files	Performs nozzle clogging detection after the preset number of files has been printed and before the next print starts.
Continuation Print	Stop / Continuous	Select whether to stop or continue printing if "Nozzle clogging" is detected.
Action	Off/1 to 10 to 100	Performs nozzle recovery (cleaning followed by nozzle checking) if "nozzle clogging" is detected.
Cleaning	Soft /Normal/ Hard	Sets the cleaning type.
Retry Count	0 to 3 times	Performs nozzle recovery (cleaning followed by nozzle checking) for the specified number of times.
² Auto Nozzle Recovery	ON/ OFF	Performs nozzle recovery automatically if "nozzle clogging" is detected. See below if you wish to perform nozzle recovery manually.  "Registering Nozzle Recovery Manually"(P. 115)
² Judgment Condition	OFF / 1 to 32 nozzles	Set the number of nozzles to be detected as clogged before "nozzle clogging" is detected. Up to 16 nozzles per row can be set. The next print will not start if "nozzle clogging" is detected during continuous printing.
Auto Maint.	-	Sets various maintenance actions to be performed automatically. Set the interval between individual maintenance actions. <ul style="list-style-type: none"> If the warning message "Replace Wasteinktank" appears, the automatic maintenance function is disabled.  "Waste Ink Tank Replacement"(P. 151)
Refresh	0.5/ 1.0 h	Sets the refresh interval (when a small amount of ink is ejected from the print head nozzles). <ul style="list-style-type: none"> W ink set: 0.1 to 0.5 h
Cleaning Interval	1 to 48 h	Sets print head cleaning intervals. This will help prevent nozzle clogging. <ul style="list-style-type: none"> W ink set: 1 to 12 h
Type	Normal /Soft/ Hard	Sets the cleaning type for head cleaning. <ul style="list-style-type: none"> W ink set Default: Soft
Print Maint.	-	Sets the maintenance to be performed automatically midway during printing.
Auto Cleaning	-	Sets the conditions to perform head cleaning after the preset number of files are printed.
Setup	File/Length/ Time/ OFF	Sets the conditions to perform head cleaning.
Interval	-	Sets head cleaning intervals.
(File)	1 to 1,000	Cleaning starts when the set number of files is exceeded.
(Length)	0.1 to 100.0 m	Cleaning starts after the length set is reached and before the next print starts.
(Time)	10 to 240 min	Cleaning starts when the set print time is exceeded.

Item		Setting ^{*1}	Details
	Type	<u>Normal</u> /Soft/ Hard	Sets the cleaning type for head cleaning. • W ink set Default: Soft
	Cleaning Check	ON/ <u>OFF</u>	Sets whether nozzle checking is performed after head cleaning is completed.
	Interval Wiping	<u>OFF</u> /3 to 255 min	Wiping starts when the set print time is exceeded.
	Refresh	Weak/ Standard/ <u>Strong</u>	Select the refresh (flushing) time during printing.
Waste Ink Tank		-	Resets or corrects the waste ink tank usage count.  "Waste Ink Tank Replacement"(P. 151)
	Reset Waste Ink Volume	-	Resets the waste ink tank usage count.  "Waste Ink Tank Replacement"(P. 151)
	Adjust Waste Ink Volume	-	Corrects the waste ink tank usage count.  "When "Check Waste Ink Tank" message appears"(P. 152)
	Tank Capacity	-	Displays the waste ink tank capacity.
Orange Maintenance		-	Prevents ink sedimentation inside the ink routes. • Use this when uneven color occurs for the orange ink.

*1. The default settings are shown underlined.

*2. Displayed only when NCU (optional) is installed.

Registering Nozzle Recovery Manually

Allows other nozzles to be used for printing if maintenance actions like nozzle washing fail to resolve ejection failures (e.g., nozzle clogging or deflection).



- Nozzle recovery can be specified for up to 20 nozzles per row. The time taken for printing remains unchanged even when nozzle recovery is set.



- Load media at least 500 mm wide. You cannot print the entire pattern if media less than 500 mm wide is used.

- 1 Position the media.**
- 2 On the LOCAL mode screen, select [MENU] > [Maintenance], then press the [ENTER] key.**
 - The Maintenance menu is displayed.
- 3 Select [Nozzle Recovery] > [Print], then press the [ENTER] key.**
 - Print a nozzle recovery pattern.
 - The Select Entry Nozzle screen appears once printing is complete.
- 4 Select the "head number and nozzle row" for nozzle recovery, then press the [ENTER] key.**
- 5 Enter the "nozzle number" for nozzle recovery, then press the [ENTER] key.**
 - Select the entry number before entering the nozzle number.
 - Nozzle recovery is set.
- 6 Press the [ENTER] key once entry is complete.**



- Select [Maintenance] > [Nozzle Recovery] > [Test Print], then select "ON" to perform nozzle recovery and test printing. 🧠 "Test Printing"(P. 67)

Nozzle Check (Option)

This is used to check for nozzle clogging before printing starts. Sets whether to perform maintenance functions automatically if nozzle clogging is detected.

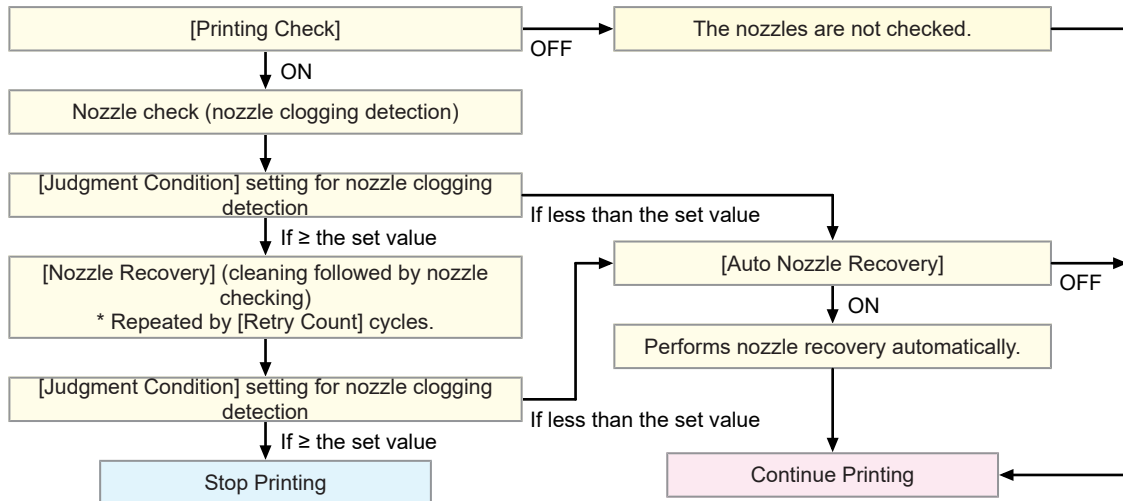

5.3 Function Setting Menu

This is used to set various operations to ensure optimal machine performance.

● Menu List

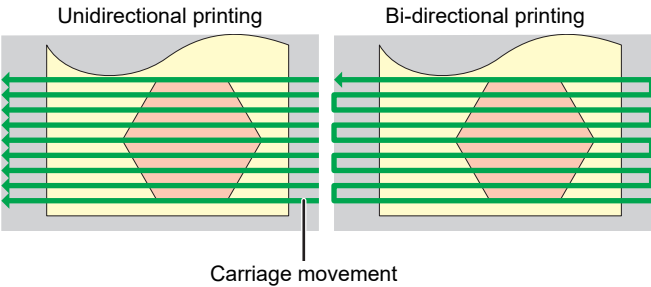
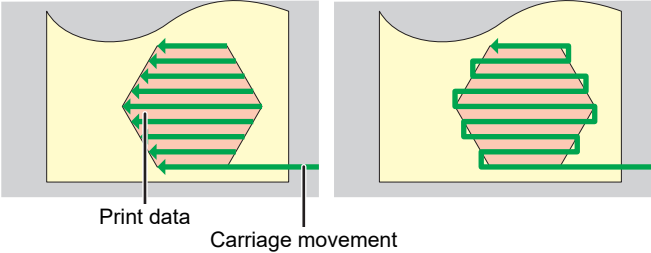
Item	Setting *1	Details
Logical Seek	<u>Host</u> /OFF/ON	<p>Sets the range of carriage movement.</p> <ul style="list-style-type: none"> • OFF: Machine size area  <p>Carriage movement</p> <ul style="list-style-type: none"> • ON: Print data area  <p>Print data Carriage movement</p>
Take-up Unit	-	Sets the take-up unit operation.
Take-up Unit	<u>ON</u> /OFF	Set to "OFF" if the take-up unit is not used.
Take-up SW	<u>Continuous</u> / Temporary	<p>Sets the function performed by the ON/OFF button on the take-up unit. Take-up unit</p> <ul style="list-style-type: none"> • Continuous: Press the button to start/stop the take-up unit. • Temporary: The take-up unit operates only while the button is pressed. The unit stops when the button is released.
Drying Time	-	Sets the time for ink to dry.
Scan	<u>Host</u> /0.0 to 9.9 sec	<p>Sets the stop time of the carriage after each scan.</p> <ul style="list-style-type: none"> • The MIMAKI RIP software (RasterLink) indicates this as "Pause Time per Scan".
Print End	<u>Host</u> /0 to 120 min	<p>Sets the stop time after printing. The next data is printed once the set time has elapsed.</p> <ul style="list-style-type: none"> • The Mimaki RIP software (RasterLink) does not allow the user to specify Print End. If the machine is set to "HOST", the time will be "0".
Pinch roller		Sets the pinch roller switching.
Skip switching PR	ON/ <u>OFF</u>	<p>Sets automatic pinch roller switching not to be performed when data is received. Refer to the following to switch pinch roller pressure. (P. 65) "Setting the Pressure and Number of Pinch Rollers to Use"(P. 65)</p>
Power Setting	-	Sets the times to turn the power on and off automatically.
Auto Power-off	5 to <u>15</u> to 60 min	Sets the time until the power is automatically turned off.

Item	Setting ^{*1}	Details
Auto Power-on	-	Sets the time to automatically turn on the power.
Setup	<u>ON/OFF</u>	Sets whether to turn on or off the power.
Time	<u>0:00</u> to 23:59	Sets the time to turn on the power.
Day	Monday to Sunday	Sets whether to turn on or off the power on each day of the week.
Nozzle Check	<u>ON/OFF</u>	Automatically executes the nozzle check function when the machine is started with auto power-on. Performs nozzle recovery (cleaning followed by nozzle checking) if "nozzle clogging" is detected.
Cleaning	<u>Soft</u> /Normal/ Hard	Sets the cleaning type.
Retry Count	<u>0</u> to 3 times	Performs nozzle recovery (cleaning followed by nozzle checking) for the specified number of times.
Use PR Number Query	<u>ON/OFF</u>	Sets whether to display the screen for entering the number of pinch rollers to be used after media width detection. <ul style="list-style-type: none"> • ON: Displays the input screen. • OFF: The "host" takes priority. Set this to "OFF" when configuring pinch roller pressure settings on this machine. Setting the Pressure and Number of Pinch Rollers to Use
WhiteSpace Setting	-	Sets the offset value from the media left and right standard margins (15 mm). <ul style="list-style-type: none"> • The left and right margins should be set to at least -5 mm when using the media holder. This eliminates the risk of printing on top of the media holder. • The Mimaki RIP software (RasterLink) does not allow the user to specify margins. If the machine is set to "Host", the offset value will be "0 mm" for the left and right margins.
Margin	-	
Margin/Left	<u>Host</u> /-10 to 85 mm	
Margin/Right		
Space Btwn PP.	<u>None</u> /10 to 500 mm	The space between prints can be eliminated for continuous printing. <ul style="list-style-type: none"> • Reducing the space length may cause media sagging, resulting in discrepancies in the distance the media is fed.
Space Feed Mode	<u>Intermittent</u> / Continuous	Alters the feed method for blank space included in the image data. <ul style="list-style-type: none"> • Intermittent: Uses intermittent feeding based on the timing of a fraction of the pass. • Continuous: Feeds forward by skipping blank parts.
View Feed	<u>ON/OFF</u>	Sets whether or not to feed the media forward to view the print results—for example, during test printing.
Feeding Before Cut	<u>ON/OFF</u>	Sets whether to feed media before cutting the media.
Auto Remote	<u>ON/OFF</u>	Sets whether to automatically switch to REMOTE mode and start printing if data is received locally.

*1. The default settings are shown underlined.

5.4 Environment Setting Menu

This is used to set various operations to ensure optimal machine performance.

● Menu List

Item	Setting *1	Details
LANGUAGE	<u>English</u> / 日本語 / Deutsch / Português / Español / Italiano / Korean	Sets the display language.
Time Set	-20 to <u>0</u> to +4 h	Sets the current time and date. (With respect to JST) <ul style="list-style-type: none"> This can be set within the range of -20 to +4 hours.
Key Buzzer	<u>ON</u> /OFF	Sets an audible tone when keys are pressed. <ul style="list-style-type: none"> Audible signals indicating errors, warnings, and operation end cannot be muted, even if "OFF" is selected for this setting.
Unit Setting	-	Set the display units.
Temp.	<u>°C</u> /°F	Sets the display unit for temperature (Celsius/Fahrenheit).
Length	<u>mm</u> /inch	Sets the display units for length and area. <ul style="list-style-type: none"> Some items are displayed in "mm" even if "inch" is selected.
Network	-	Sets the network address. The machine must be restarted to enable this setting.
Check IP Address	-	Displays the machine's current IP address. <ul style="list-style-type: none"> It may take some time to determine the IP address. If the IP address cannot be determined, the display will indicate "0.0.0.0".
Check MAC Address	-	Displays the machine's current MAC address.
DHCP	<u>ON</u> /OFF	Select "ON" to use the IP address assigned by the DHCP server.
AutoIP	<u>ON</u> /OFF	Select "ON" to use the IP address set by the AutoIP protocol. Note that DHCP takes priority if DHCP is set to "ON".
Ip Address	-	Sets the IP address used by the machine. <ul style="list-style-type: none"> This can be set when both [DHCP] and [AutoIP] are disabled.
Default Gateway	-	Sets the default gateway used by the machine. <ul style="list-style-type: none"> This can be set when both [DHCP] and [AutoIP] are disabled.
DNS Address	-	Sets the DNS server address used by the machine. <ul style="list-style-type: none"> This can be set when both [DHCP] and [AutoIP] are disabled.
Sub Net Mask	-	Sets the subnet mask used by the machine. <ul style="list-style-type: none"> This can be set when both [DHCP] and [AutoIP] are disabled.
Remote Control	-	An application (MRA: Mimaki Remote Access) is required to use the remote control function. MRA is a remote access tool installed on a computer or smartphone that allows viewing of product information and panel operation from a remote location away from the machine (within the same network segment).
Setup	<u>Enable</u> / Disable	Enable/disable remote control.

Item	Setting ^{*1}	Details
	PIN code	<p data-bbox="614 185 1332 246">Enter the same PIN code as MRA. The PIN code is used for authentication between the machine and MRA.</p> <ul data-bbox="630 253 1332 313" style="list-style-type: none"> <li data-bbox="630 253 1332 313">• When the machine is set to "0000", MRA can access the machine with any PIN code.
	KeyLife	<p data-bbox="614 336 1420 396">Sets the time interval before disconnecting the machine and MRA if no operations are performed using MRA.</p>
Machine Reset	-	Initializes the details set.

*1. The default settings are shown underlined.

5.5 Machine Status Menu

This is used to check machine information.

● Menu List

Item		Details
Usage	WIPING	The number of wiping cycles is displayed.
	Waste Ink Tank	Displays the approximate level of waste ink in the waste ink tank as a percentage. <ul style="list-style-type: none"> To reset waste ink levels, press the [FUNC1] key while the level is displayed.
	Print Length	Displays the total length printed.
	Print Area	Displays the total area printed.
	Use Time	Displays the total time the power has been turned on.
	Capping Use Days	Displays the number of days since the cap was replaced.
Version		Displays the machine firmware and other versions.
Error History		Displays the error and warning history. <ul style="list-style-type: none"> These are listed in chronological order. Use the keys to cycle through occurrence time/date and error/warning information.
List		This is used to print machine information.

5.6 Cutting Menu

For setting the various cutting function operations

● Menu List

Item	Setting ^{*1}	Details
Mark Detect	-	Enter the conditions of the printed register marks.
Detect	ON/OFF	Set this to ON to cut cutting data with register marks.
Form	Type1 /Type2/ Zero Margin	Select three types of register mark shapes. "Register Marks"(P. 100)
Size	5 to 10 to 40 mm	Set the register mark length (B). "Standards for Register Mark Length and Line Width"(P. 101)
Offset X	-5.00 to 5.00 mm	Change the position of the register mark origin. If the cut position shifts in the same direction, change the position of the origin.
Offset Y	-5.00 to 5.00 mm	<ul style="list-style-type: none"> • If "ERROR C37 Mark Org" is displayed, change the layout by referring to the following. "Reading Range of Register Marks"(P. 103)
Detect End Key Start	ON/OFF	If you press the [END] key on the LOCAL mode screen, the cutter unit moves over the platen so that register marks can be detected.
Sensor sensitivity	1 to 7	Check the sensitivity of the register mark sensor. Normally, set this to "4". <ul style="list-style-type: none"> • If it cannot detect the register marks: Increase sensitivity. • If it mis-detects the register marks: Decrease sensitivity.
Mark FillUp	ON/OFF	When the "Fill around the registration marks" function of the RIP software is enabled, set this to "ON".
Detect Area	-	Sets the automatic register mark detection area.
Scan Dir.	Default /0 cm to machine width	Sets the scan direction for automatic register mark detection. <ul style="list-style-type: none"> • When set to [DEFAULT], the detection operation is performed at half the media width.
Feed Dir.	10 to 50 cm	Sets the media feed direction for automatic register mark detection.
Offset X	0 to 100 cm	Sets the automatic detection start position for the next register mark.

Item	Setting ^{*1}	Details
Cut Mode	Normal/ HighSpd/ Quality	Sets the cutting quality. <ul style="list-style-type: none"> • Normal: Normally, use this setting. • HighSpd: This cuts media in a short period of time. This is not suitable for use with heavy media. • Quality: This puts priority on the cutting quality, and limits the cutting speed to 20 cm/s. Select "Quality" when cutting the following data. <ul style="list-style-type: none"> – Text not larger than 10 mm – Data with many acute angles – Intricate data (However, cut lines may be jagged depending on the data. If this occurs, change the setting to "HighSpd" to make cut lines smoother.)
Copy	-	Cut the data stored in the receive buffer of the machine by the specified number. 🖨️ "Copying the Last Data"(P. 124)
No. Copies	1 to 999	Enter the number of copies.
Interval	0 to 30 mm	Select the cut data interval.
Tool Change	-	Select this when replacing tools. 🖨️ "Installing Cutting Tools"(P. 84)
Setup Sub Menu	-	Useful functions when cutting.
Up Speed	-	Set the movement speed of the media and carriage while the tool is up.
Up Speed X	AUTO/5 to 30 cm/s	Sets the media feed speed. Setting a slower speed can reduce media offsets.
Up Speed Y	AUTO/5 to 30 cm/s	Sets the carriage scan speed.
Dummy cut	ON/OFF	Cuts the media to make the cutting blade face a certain direction after media detection or tool changes. (Performs a dummy cut in front of the pinch rollers which are closest to both ends of the cutter unit.) <div data-bbox="619 1279 954 1480" data-label="Image"> </div> <p>If you wish to avoid damage to the media or cut cut-out characters, set this to OFF. Perform test cutting to adjust the direction of the cutting blade. 🖨️ "Test Cutting"(P. 93) If the tool condition is set to "PEN", dummy cutting is disabled.</p>
Sheet Type	Standard/ Heavy	Set the weight of the set media.
Adj-prs Offset	-9 to 0 to 9	When cutting the corners, the pressure is automatically decreased (by about 5 g) to prevent the media from lifting up. As a result, the cutting blade might not rotate smoothly and may leave uncut parts. Adjust the pressure for cutting the corners if they are left uncut.
Vacuum Fan	Weak/ Standard/ Strong/OFF	Sets the force with which the medium is held down during cutting. Ordinarily, use "Weak".
Over Cut	OFF/0.1 to 1.0 mm	Overlaps the start and end points so that no part of the media is left uncut. 🖨️ "Preventing Uncut Media"(P. 125)

Item		Setting ^{*1}	Details
	Corner Cut	<u>ON/OFF</u>	Performs over cutting at corners other than the start and end point. "Preventing Uncut Media"(P. 125)
	Curve Mode	<u>Fast</u> /Slow	If the cut line becomes twisted, set this to "Slow". This can prevent twisting but decreases cutting speed.
	Setup Reset	-	Initializes the details set.
Maintenance		-	
	Marks Sensor	-	
	Sensor Check	-	Check the responsiveness of the register mark sensor. "Adjusting the Position of the Register Mark Sensor"(P. 162)
	Pointer Offset	-	Adjust the position of the light pointer when the positions of the register mark sensor and light pointer do not match. "Correcting the LED Pointer Position"(P. 163)
	Sample Cut	-	Use a sample stored in the unit for cutting to troubleshoot problems when data cannot be cut properly. "Investigating the Cause of Cutting Failures"(P. 164)
	Auto Media Cut	-	Cuts the specified number of media sheets at the specified length.
	Cut Interval	10 to 10,000 mm	Sets the cut length.
	Front Cut Off	0 to 500 mm	The front edge of the media can be cut off if cut diagonally. Sets the cut length.
	Count	1 to 9,999 times	Sets the number of media pieces to be cut.
	Scale Adjust	-	When printing and cutting without register marks, perform corrections when the media deviates to the left or right side of the scan direction.

*1. The default settings are shown underlined.

Copying the Last Data

You can cut the data stored in the receive buffer of the machine by the specified number (up to 999 sheets).

- The last cutting data is stored in the receive buffer. When new data is received, the already saved data is overwritten.
- Reset the origin before executing the copy function. Failure to do so will result in overlap cutting.

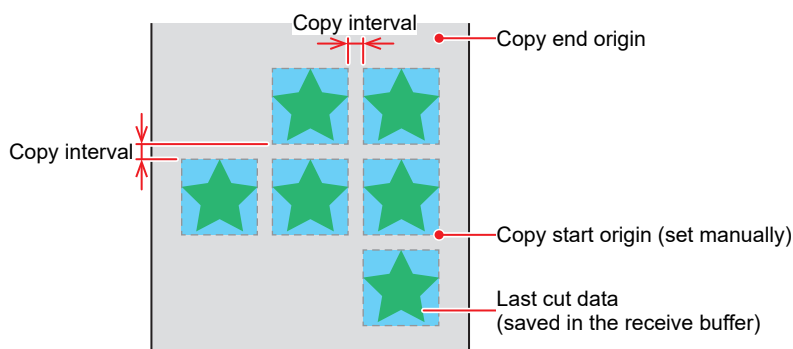



- With the following data, only one sheet can be cut, regardless of the number of copies specified.
 - (1) Data received from MIMAKI RIP software (RasterLink).
 - (2) Data for which "Sheet Feed Origin Renewal" has been selected in the MIMAKI cutting software (FineCut).



- When sending the cut data from the PC, wait for at least 5 seconds before sending the next data. If the next data is sent within 5 seconds, both pieces of data may be copied.

Preventing Uncut Media

Overlapping the start and end points can prevent the media from being left uncut. Configure this setting for very flexible media.

If the setting is too large, the print may also be cut. Alter the setting while checking using a test cut. "Test Cutting"(P. 93)

● Over Cut

The machine cuts the media in front of the cutting start point by the set value. The media is overcut by the set value at the end point.

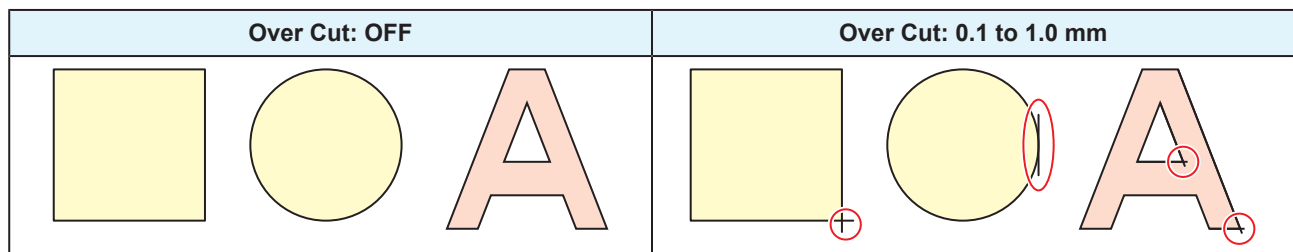

● Corner Cut

When the Over Cut setting value is entered, Corner Cut is displayed. The machine performs over cutting at corners other than the start and end point.

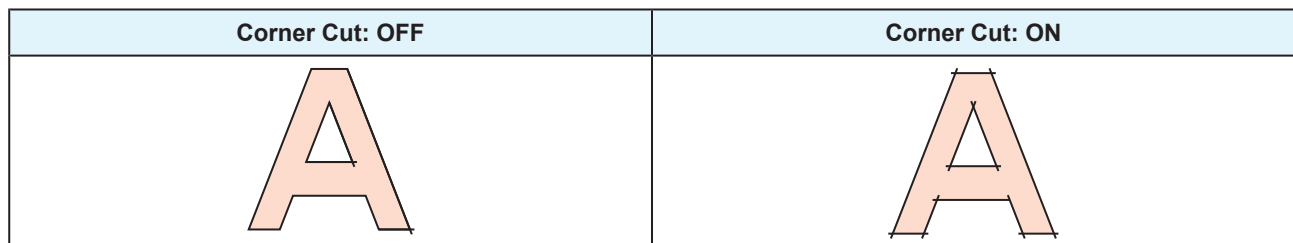

Chapter 6 Maintenance



This chapter

To ensure years of precise performance, maintain the machine periodically based on frequency of use.

Read the maintenance precautions thoroughly before maintaining this product.

Maintenance Precautions	128	Replacement of Consumable Item	143
Maintenance Methods	129	Consumable Item Replacement Timing	143
Maintenance Items and Timing	129	Wiper Replacement	144
Ink Maintenance	130	Cap Replacement	145
Cap Rubber Cleaning	130	Replacing the Absorber Around the Station	146
Carriage Underside Cleaning	131	Pinch Roller Replacement	148
Wiper Cleaning	132	Media Holder Replacement	148
Cleaning the NCU (Option)	134	Media Cutter Replacement	150
DAS (Automatic Correction Function) Sensor	135	Waste Ink Tank Replacement	151
Cleaning	135	Cutter for Cutting Machine	154
Ink Discharge Channel Cleaning	136	Pen Line Replacement	154
Media Sensor Cleaning	137		
Media Cutter Cleaning	137		
Media Holder Cleaning	139		
Jam Sensor Detecting Plate Cleaning	139		
Platen Cleaning	140		
Cover (Exterior) Cleaning	140		
When this Printer is Left Unused for a Long Time	140		

6.1 Maintenance Precautions



- This machine includes parts that must be replaced periodically. We therefore recommend taking out a maintenance contract. Carry out maintenance periodically and replace consumable items to prevent quality defects and accidents.

⚠ WARNING



- Clean periodically. Debris and dust will accumulate on electrical components when the machine is used for extended periods. There is a risk of failure, electric shock, or fire due to current leakage.
- Do not clean by blowing—e.g., avoid using air blowers. Doing so may lead to failure, electric shock, or fire involving the machine if airborne debris or dust gets inside electrical components. Wipe using a soft cloth soaked in diluted neutral detergent and thoroughly wrung out. A vacuum cleaner may also be used for cleaning.



- Be careful to prevent liquids from getting inside the machine. Otherwise there is a risk of failure, electric shock, or fire.

⚠ CAUTION



- For heavy soiling, wipe using a soft cloth soaked in diluted neutral detergent and thoroughly wrung out.



- Pay close attention to ventilation and be sure to wear safety glasses, gloves, and a mask when handling ink, maintenance liquid, waste ink, or other solutions used with the machine. Leaking ink may adhere to the skin or get into the eyes or mouth.





NOTICE



- Never touch the print head nozzle surface. Do not allow water or alcohol to come into contact with the print nozzle surface. This will increase the risk of machine failure or ejection failures (e.g., nozzle clogging or deflection).
- Do not use cotton swabs to clean around the head or carriage. Fibers from cotton swabs may adhere to the head nozzle surface and lead to ejection failures (e.g., nozzle clogging or deflection).
- Do not splash ink or maintenance liquid on the covers. Exposure to splashing ink or maintenance liquid may damage or deform the cover.
- Do not use benzine, thinner, or any chemical agent containing abrasives. Use of these chemicals may result in damage to or deformation of parts.
- Do not move the carriage by hand. To move the carriage, use the carriage out function on the menu.

6.2 Maintenance Methods

Maintenance Items and Timing

Timing	Item
Every three days, at the start of the work	Shake the ink.  "Ink Maintenance"(P. 130)
At the end of the week's work	Clean the cap rubber.  "Cap Rubber Cleaning"(P. 130)
	Clean the underside of the carriage.  "Carriage Underside Cleaning"(P. 131)
	Check the waste ink levels in the waste ink tank.  "When "Check Waste Ink Tank" message appears"(P. 152)
	Clean around the wiper.  "Wiper Cleaning"(P. 132)
Every month	Clean the NCU. (NCU is optional.)  "Cleaning the NCU (Option)"(P. 134)
	Clean the DAS sensor.  "DAS (Automatic Correction Function) Sensor Cleaning"(P. 135)
	Clean the ink discharge channel.  "Ink Discharge Channel Cleaning"(P. 136)
	Clean the media sensor.  "Media Sensor Cleaning"(P. 137)
	Clean the media cutter.  "Media Cutter Cleaning"(P. 137)
	Clean the media holder.  "Media Holder Cleaning"(P. 139)
	Clean the jam sensor detecting plate.  "Jam Sensor Detecting Plate Cleaning"(P. 139)
	Clean the platen.  "Platen Cleaning"(P. 140)
When not used for more than a week	Clean the cap and wash the ink discharge channels. After cleaning, store without turning off the main power supply.  "When this Printer is Left Unused for a Long Time"(P. 140)

Items Required for Maintenance

To order replacement consumable items, contact your local dealer or our service office. For more information on consumable items, refer to our website (<https://mimaki.com/supply/inkjet.html>).



- Do not store consumable items in locations where children may enter.

Ink Maintenance

If ink constituents are sedimented, the ink density may become uneven. We recommend shaking the Ink pack periodically to keep printing consistent.

Solvent ink: once a month.

● Shake the Ink pack

1 Shake the Ink pack to the left and right slowly at least 20 times.

- Shake the bottle slowly from left to right to ensure that the ink moves inside.

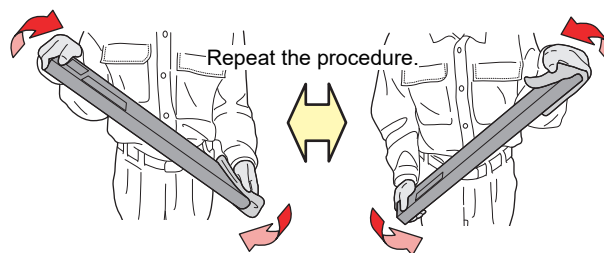

- When using an ink cartridge with ink remaining, hold a paper towel over the gap between the ink cartridge slot and the side and shake slowly with the ink cartridge tilted upright.



Needle slot



Gap on the side

Cap Rubber Cleaning

The cap prevents the print head nozzle surface from drying out. Continuing to use a dirty cap may affect ink take-up and lead to ejection failures (such as nozzle clogging or deflection).



- Be careful to avoid leaving fragments from the cleaning stick behind when cleaning. These fragments will increase the risk of ejection failures (e.g., nozzle clogging or deflection).

1 On the LOCAL mode screen, select [MENU] > [Maintenance], then press the [ENTER] key.

- The Maintenance menu is displayed.

2 Select [Station Maint.] > [Carriage Out] > [Move To Platen Right End], then press the [ENTER] key.

- The carriage moves over the platen.

3 Open the maintenance cover (right side).

4 Clean the cap rubber.

- Wipe off any ink and dust adhering using a cleaning stick moistened with maintenance liquid. Wipe off the maintenance liquid. Make sure none remains.
- Clean the areas indicated in red (the entire interior and exterior of the cap rubber and the tabs) in the diagram.

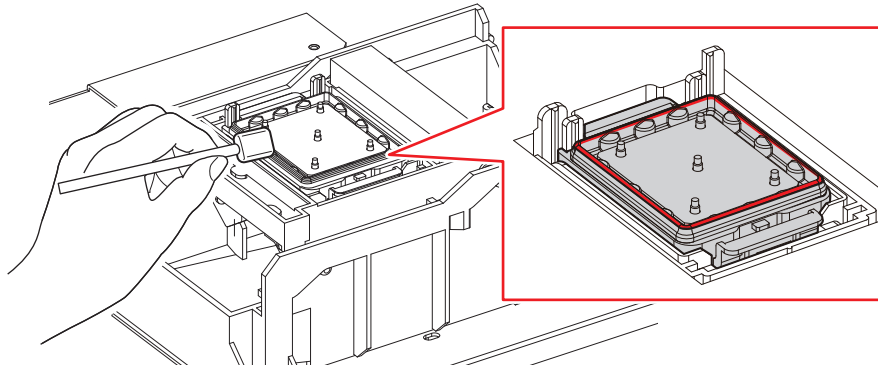

5 Once cleaning is complete, close the cover, then press the [ENTER] key.

Carriage Underside Cleaning

The underside of the carriage becomes coated with ink wiped off by the wiper. Continuing to use the dirty carriage underside will rub dried ink and attached dust on to the media, resulting in contaminated prints.

The print head uses an extremely delicate mechanism. Take great care when handling it.



- Be careful to avoid leaving fragments from the cleaning stick behind when cleaning. These fragments will increase the risk of ejection failures (e.g., nozzle clogging or deflection).

1 Remove the maintenance cover (upper left side).

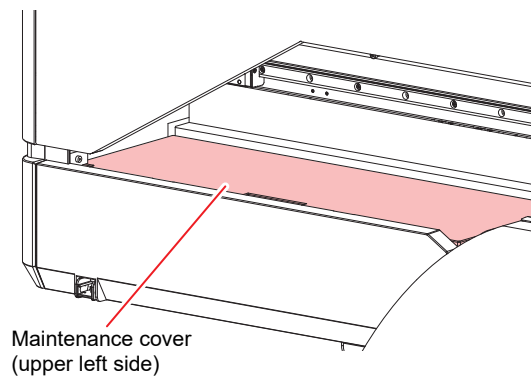

2 On the LOCAL mode screen, select [MENU] > [Maintenance], then press the [ENTER] key.

- The Maintenance menu is displayed.

3 Select [Station Maint.] > [Carriage Out] > [Move To Maint. Space], then press the [ENTER] key.

- The carriage moves to the maintenance space.

4 Open the maintenance cover (left side).

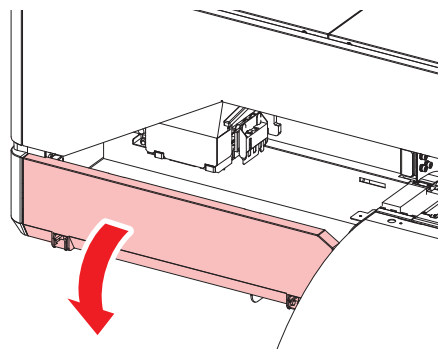

5 Clean around the print head.

- Wipe off any ink and dust adhering using a cleaning stick moistened with maintenance liquid. Wipe off the maintenance liquid. Make sure none remains.

Clean the print head sides using a cleaning stick.

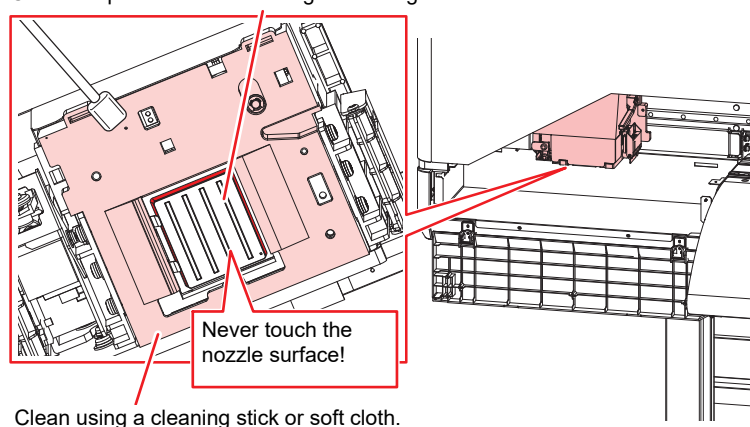

Clean using a cleaning stick or soft cloth.



- Never touch the print head nozzle surface.

6 Once cleaning is complete, press the [ENTER] key.

- The carriage moves back to its original position.

7 Close the maintenance cover (left side), then attach the maintenance cover (upper left side).

Wiper Cleaning

The wiper wipes off ink adhering to the print head nozzle surface. Continuing to use with a dirty wiper may cause dried ink and attached dust to damage the head nozzle surface, and could lead to ejection failures (e.g., nozzle clogging or deflection).



- Be careful to avoid leaving fragments from the cleaning stick behind when cleaning. These fragments will increase the risk of ejection failures (e.g., nozzle clogging or deflection).

1 On the LOCAL mode screen, select [MENU] > [Maintenance], then press the [ENTER] key.

- The Maintenance menu is displayed.

2 Select [Station] > [Carriage Out] > [Move To Platen Right End], then press the [ENTER] key.

- The carriage moves over the platen.

3 Open the maintenance cover (right side).

4 Remove the wiper.

- Hold the lugs on both sides of the wiper bracket, then pull out the wiper.

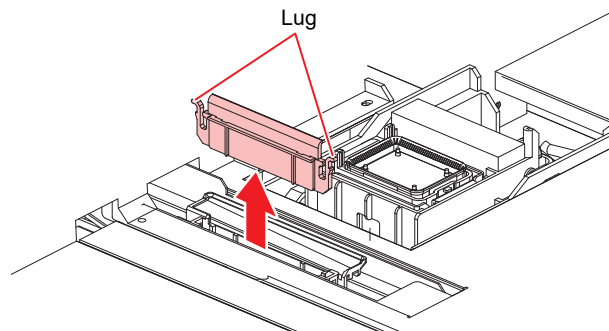

5 Clean the wiper and bracket.

- Wipe off any ink and dust adhering using a cleaning stick moistened with maintenance liquid. Wipe off the maintenance liquid. Make sure none remains.

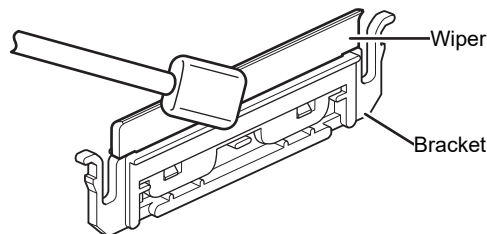

- Replace dirty or warped wipers with new ones.  ["Wiper Replacement"\(P. 144\)](#)

6 Clean the wiper slider.

- Wipe off any ink and dust adhering using a cleaning stick moistened with maintenance liquid. Wipe off the maintenance liquid. Make sure none remains.

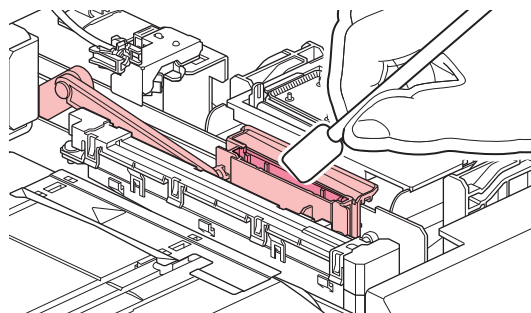

7 Reattach the wiper at the original position.

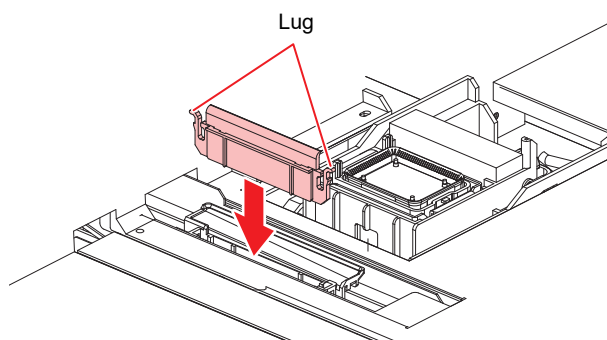

- Do not remove the absorber pad in the pad case. Doing so may result in leaking ink.

8 Once cleaning is complete, close the cover, then press the [ENTER] key.

Cleaning the NCU (Option)

The NCU uses a sensor to monitor the ink droplets ejected from the print head nozzles. Continuing to use the dirty NCU may prevent the nozzle check function from operating correctly.



- Be careful to avoid leaving fragments from the cleaning stick behind when cleaning. These fragments will increase the risk of ejection failures (e.g., nozzle clogging or deflection).

1 On the LOCAL mode screen, select [MENU] > [Maintenance], then press the [ENTER] key.

- The Maintenance menu is displayed.

2 Select [Station Maint.] > [Carriage Out] > [Move To Platen Right End], then press the [ENTER] key.

- The carriage moves over the platen.

3 Open the maintenance cover (right side).

4 Clean the NCU.

- Wipe off any ink and dust adhering using a cleaning stick moistened with maintenance liquid. Wipe off the maintenance liquid. Make sure none remains.

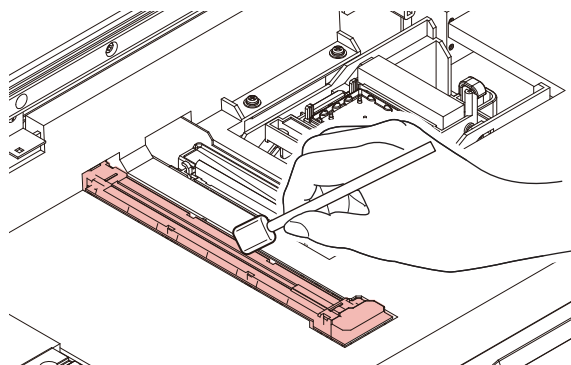



- Insert the cleaning stick as far as the line shown in the illustration.

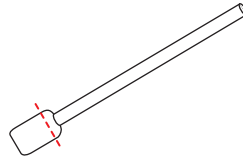

- 5 Once cleaning is complete, close the cover, then press the [ENTER] key.

DAS (Automatic Correction Function) Sensor Cleaning

The DAS sensor is located on the carriage underside. If dust or debris accumulates on the sensor, DAS (Media Setting Menu) may not function.

- 1 Remove the maintenance cover (upper left side).

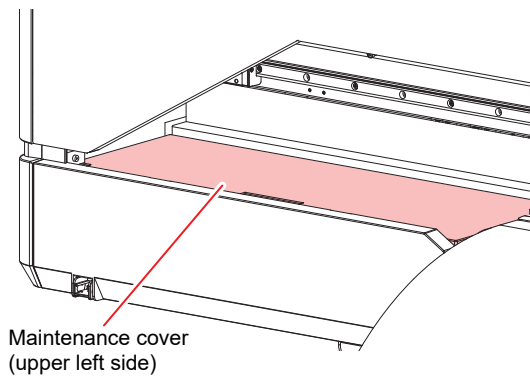

- 2 On the LOCAL mode screen, select [MENU] > [Maintenance], then press the [ENTER] key.
 - The Maintenance menu is displayed.
- 3 Select [Station Maint.] > [Carriage Out] > [Move To Maint. Space], then press the [ENTER] key.
 - The carriage moves to the maintenance space.
- 4 Open the maintenance cover (left).

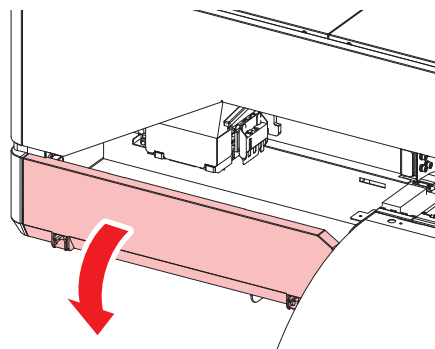

5 Clean the DAS sensor.

- Wipe clean using cotton swabs or a soft cloth.

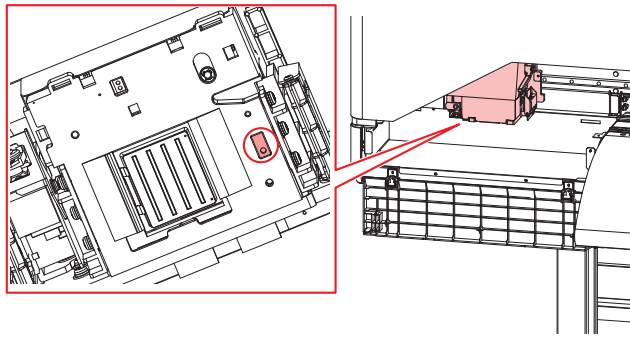

- For heavy soiling, wipe using a soft cloth soaked in diluted neutral detergent and thoroughly wrung out.

6 Once cleaning is complete, press the [ENTER] key.**7 Close the maintenance cover (left side), then attach the maintenance cover (upper left side).**

Ink Discharge Channel Cleaning

Clean the ink discharge channel regularly to prevent clogging of the ink discharge channel below the cap.

1 On the LOCAL mode screen, select [MENU] > [Maintenance], then press the [ENTER] key.

- The Maintenance menu is displayed.

2 Select [Station Maint.] > [Pump tube cleaning], then press the [ENTER] key.**3 Open the maintenance cover (right side).****4 Fill the cap with maintenance liquid.**

- Use a syringe to draw up some maintenance liquid and fill until it almost overflows from the cap.

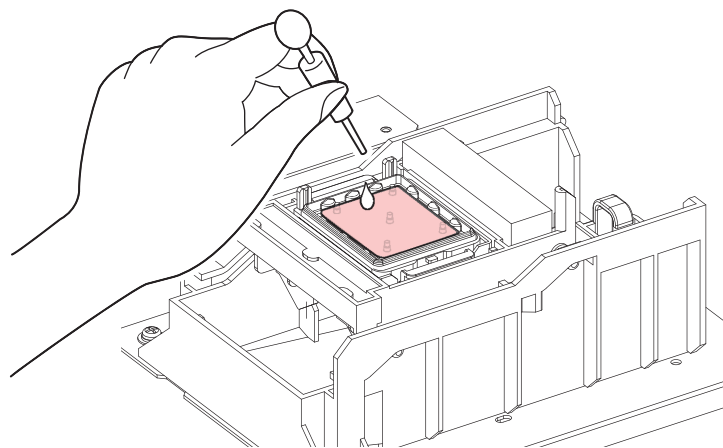
**5 Close the maintenance cover (right side), then press the [ENTER] key.**

- Pump tube (ink discharge channel below the cap) washing starts.

Media Sensor Cleaning

Media sensors are located on the rear cover and carriage underside. The media cannot be detected correctly if dust or debris accumulates on the sensors. Remove any debris using cotton swabs or a soft cloth.

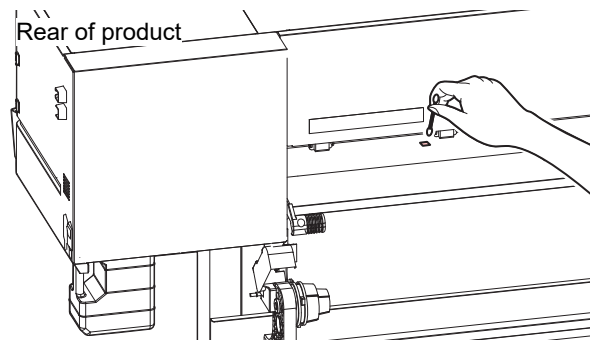

● Cleaning the carriage underside sensor

- 1** On the LOCAL mode screen, select [MENU] > [Maintenance], then press the [ENTER] key.
 - The Maintenance menu is displayed.
- 2** Select [Station Maint.] > [Carriage Out] > [Move To Maint. Space], then press the [ENTER] key.
 - The carriage moves to the maintenance space.
- 3** Clean the media sensor.
- 4** Once cleaning is complete, press the [ENTER] key.

Media Cutter Cleaning

Continuing to use a dirty media cutter may cause dust to collect on the head nozzle surface or the cutter blade to grow dull.



- Avoid touching the cutter blade. Failure to do so may result in injury.

- 1** On the LOCAL mode screen, select [MENU] > [Maintenance], then press the [ENTER] key.
 - The Maintenance menu is displayed.
- 2** Select [Station Maint.] > [Carriage Out] > [Move To Platen Right End], then press the [ENTER] key.
 - The carriage moves over the platen.
- 3** Open the maintenance cover (right side).



- The carriage can be moved by hand. Move the carriage slowly to a position allowing easy access while working.

4 Remove the media cutter.

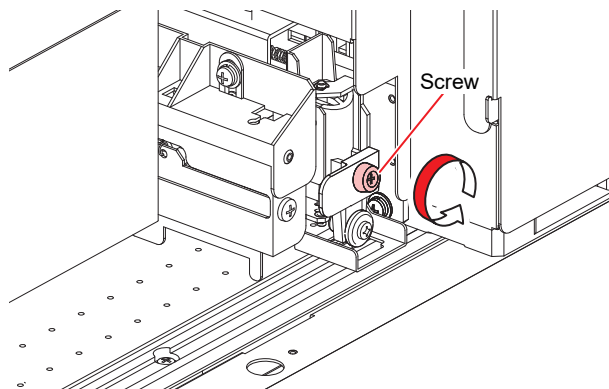

5 Clean both sides of the media cutter.

- Wipe off any adhesive paste, ink and dust adhering using a cleaning stick moistened with industrial alcohol. Wipe off any industrial alcohol so that none remains.

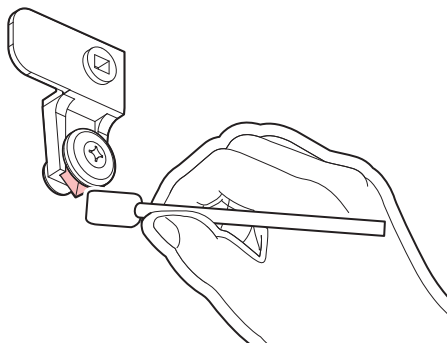

6 Return the media cutter to its original position.



- Tighten the screw securely. A loose screw may cause cutter or platen damage.

7 Check the position of the media cutter.

- Lift up the media cutter by hand if it has dropped down.

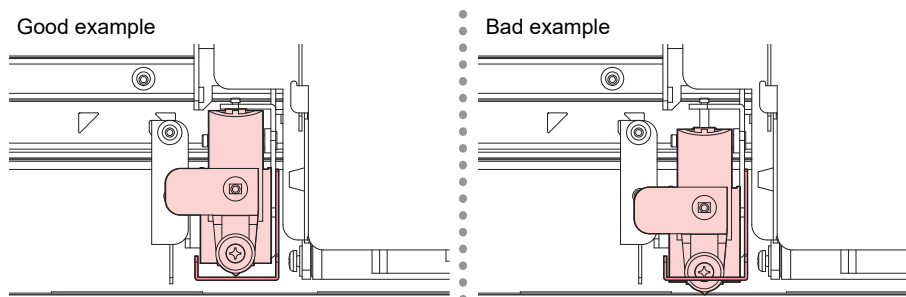

8 Once cleaning is complete, close the cover, then press the [ENTER] key.

Media Holder Cleaning

Continuing to use a dirty media holder will prevent correct media detection or proper feeding of the media. It will also cause dried ink and attached dust to rub against the head nozzle surface and lead to ejection failures (e.g., nozzle clogging or deflection).

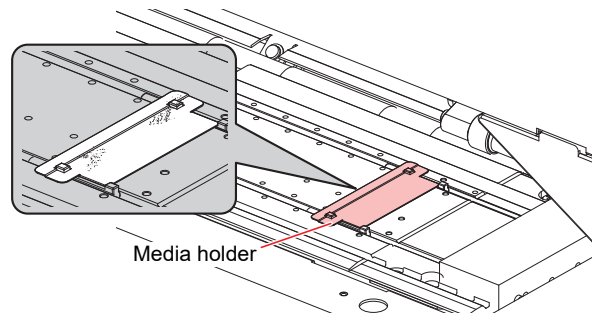

- Turn off the main power supply and unplug the power cable before carrying out maintenance.



- Be careful to prevent liquids from getting inside the machine. Otherwise there is a risk of failure, electric shock, or fire.



- For heavy soiling, wipe using a soft cloth soaked in diluted neutral detergent and thoroughly wrung out.

Jam Sensor Detecting Plate Cleaning

Continuing to use the dirty carriage underside will rub dried ink and attached dust on to the media, resulting in contaminated prints.

- 1 On the LOCAL mode screen, select [MENU] > [Maintenance], then press the [ENTER] key.**
 - The Maintenance menu is displayed.
- 2 Select [Station Maint.] > [Carriage Out] > [Move To Maint. Space], then press the [ENTER] key.**
 - The carriage moves to the maintenance space.
- 3 Clean the jam sensor detecting plate.**
 - Clean the jam sensor detecting plate underside at the left and right sides of the carriage.
 - Wipe off any ink and dust adhering using a cleaning stick moistened with maintenance liquid. Wipe off the maintenance liquid. Make sure none remains.

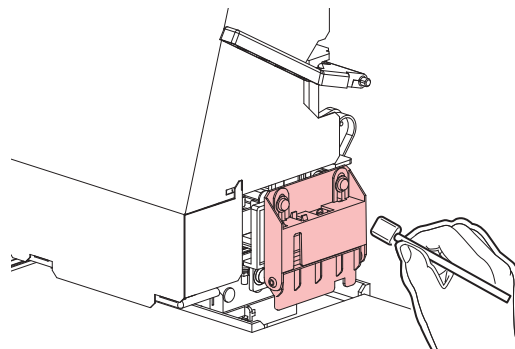

- 4 Once cleaning is complete, press the [ENTER] key.**

Platen Cleaning

Continuing to use the dirty platen will prevent proper feeding of the media. It will also cause dried ink and attached dust to rub against the head nozzle surface and lead to ejection failures (e.g., nozzle clogging or deflection).



- Turn off the main power supply and unplug the power cable before carrying out maintenance.



- Be careful to prevent liquids from getting inside the machine. Otherwise there is a risk of failure, electric shock, or fire.



- The grooves in which the media holder slides and the media is cut are susceptible to dust accumulation. Remove any debris carefully.



- For heavy soiling, wipe using a soft cloth soaked in diluted neutral detergent and thoroughly wrung out.

Cover (Exterior) Cleaning

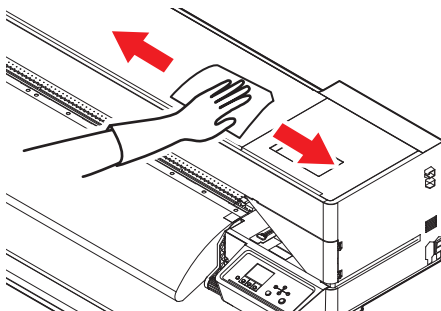

- Be careful to prevent liquids from getting inside the machine. Otherwise there is a risk of failure, electric shock, or fire.



- For heavy soiling, wipe using a soft cloth soaked in diluted neutral detergent and thoroughly wrung out.

When this Printer is Left Unused for a Long Time

Clean as follows if the product is not used for one week or longer:

Check beforehand

Is [Near End] or [Ink End] displayed?

- Maintenance liquid and ink is aspirated during the washing operation. Washing is not possible if an error occurs during this process. Replace with new ink.



- Do not turn off the main power supply. Turning off the main power supply will disable the automatic maintenance function (including nozzle clogging prevention function and ink discharge channel cleaning function). This increases the risk of ejection failures (such as nozzle clogging or deflection).

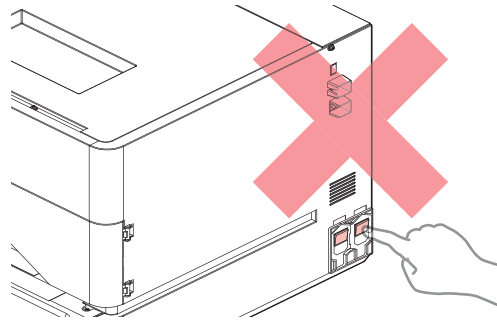

- Do not leave media loaded on the platen. This may leave irregularities or ripples in the media.





When the machine is not in use, raise the clamp lever to **separate the pinch rollers from the grit rollers**.

- Leaving the pinch rollers lowered may cause them to become deformed and prevent media from being fed correctly.
- Leaving media loaded will subject it to force from the pinch rollers, which may leave pinch roller marks on it.



- Perform the following if the "Check Waste Ink Tank" message appears on the display.
 ["Waste Ink Tank Replacement"\(P. 151\)](#)

- 1 On the LOCAL mode screen, select [MENU] > [Maintenance], then press the [ENTER] key.**
 - The Maintenance menu is displayed.
- 2 Select [Station Maint.] > [Custody Wash], then press the [ENTER] key.**
 - The carriage moves over the platen.
- 3 Open the maintenance cover (right side).**
- 4 Clean the wiper.**
 -  ["Wiper Cleaning"\(P. 132\)](#)
- 5 Clean the cap rubber.**
 -  ["Cap Rubber Cleaning"\(P. 130\)](#)
- 6 Once cleaning is complete, press the [ENTER] key.**
- 7 Fill the cap with maintenance liquid.**



- Use a syringe to draw up some maintenance liquid and fill until it almost overflows from the cap.

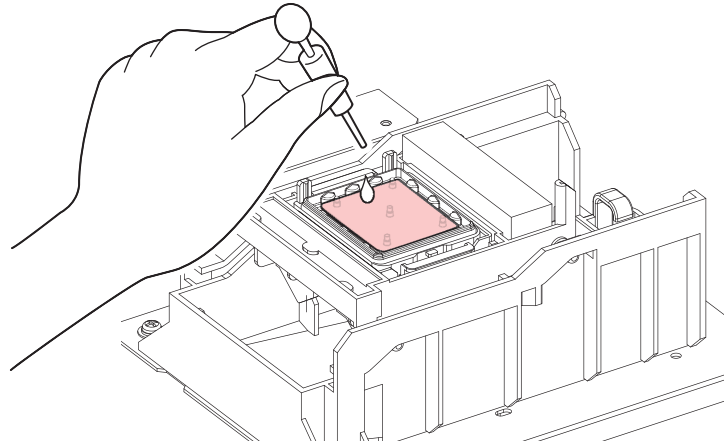

- 8** Close the maintenance cover (right side).
- 9** Set the exposure time, then press the [ENTER] key.
 - Cleaning is performed automatically once print nozzle washing has ended.
 - [Please wait] is displayed.
- 10** When [Maintenance liquid solution the liquid.] appears again, open the maintenance cover (right side), and fill the cap with cleaning solution in the same way as Step 7.
- 11** Close the maintenance cover (right side).

6.3 Replacement of Consumable Item

To order replacement consumable items, contact your local dealer or our service office. For more information on consumable items, refer to our website (<https://mimaki.com/supply/inkjet.html>).













- Do not store consumable items in locations where children may enter.



- When disposing of consumable items, contact an industrial waste disposal operator or dispose of the product in accordance with the local laws and regulations.

Consumable Item Replacement Timing

Timing	Item
When dirty	 "Replacing the Absorber Around the Station"(P. 146)
When ejection failures cannot be remedied	 "Cap Replacement"(P. 145)  "Wiper Replacement"(P. 144)
When damaged	 "Cap Replacement"(P. 145)  "Pinch Roller Replacement"(P. 148)  "Media Holder Replacement"(P. 148)  "Media Cutter Replacement"(P. 150)  "Cutter for Cutting Machine"(P. 154)  "Pen Line Replacement"(P. 154)
When "Check Waste Ink Tank" appears on the display	 "Waste Ink Tank Replacement"(P. 151)

Wiper Replacement

The machine maintains a count of the number of wiping cycles. The "Replace Wiper" message appears when a preset count is reached. Replace dirty or warped wipers with new ones.

- 1** "Replace Wiper" appears on the display.
- 2** On the LOCAL mode screen, select [MENU] > [Maintenance], then press the [ENTER] key.
 - The Maintenance menu is displayed.
- 3** Select [Station Maint.] > [Replace Wiper], then press the [ENTER] key.
 - The carriage moves over the platen.
- 4** Open the maintenance cover (right side).
- 5** Remove the wiper.
 - Hold the lugs on both sides of the wiper bracket, then pull out the wiper.

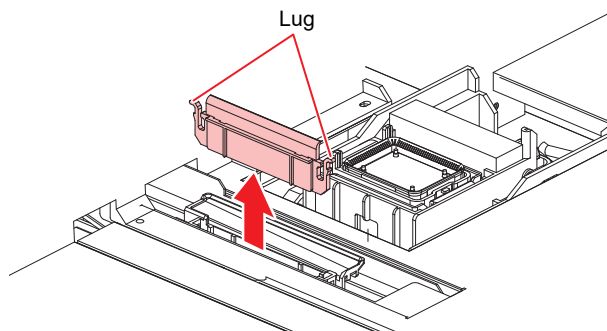

- 6** Clean the wiper slider.
 - Wipe off any ink and dust adhering using a cleaning stick moistened with maintenance liquid. Wipe off the maintenance liquid. Make sure none remains.

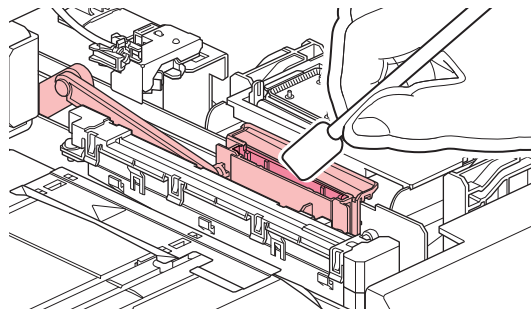

7 Mount a new wiper.

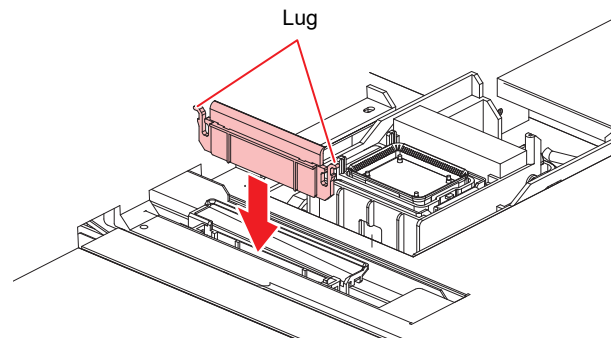

8 Once replacement is complete, close the cover, then press the [ENTER] key.

- The wiper usage count is reset.

9 Once replacement is complete, close the cover, then press the [ENTER] key.

Cap Replacement

If ejection failures (e.g., nozzle clogging or deflection) remain unresolved even after cleaning, replace with a new cap.



- Be sure to replace the cap if you observe any scratches or other damage on the rim.

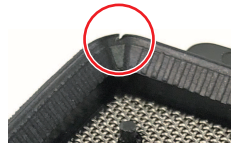

- We recommend replacing the cap every six to twelve months.

1 On the LOCAL mode screen, select [MENU] > [Maintenance], then press the [ENTER] key.

- The Maintenance menu is displayed.

2 Select [Station Maint.] > [Replace Cap], then press the [ENTER] key.

- The carriage moves over the platen.

3 Open the maintenance cover (right side).

4 Remove the cap.

- Squeeze the lugs on either side of the cap and pull off.

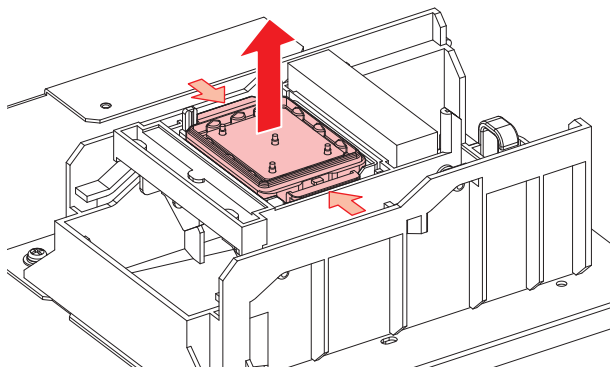
**5 Apply maintenance liquid.**

- Use a syringe to apply two or three drops of maintenance liquid to the hole at the front.

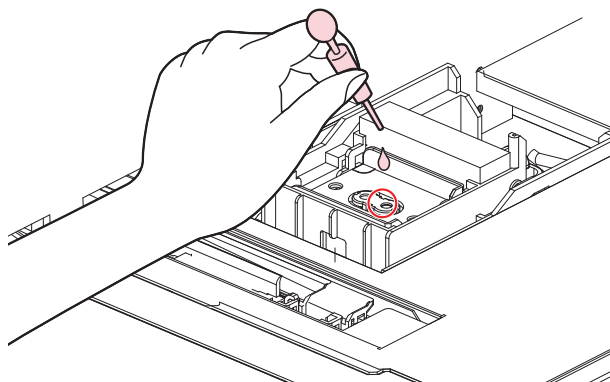
**6 Mount a new cap.**

- Position with the slot at the front and push in until it clicks.

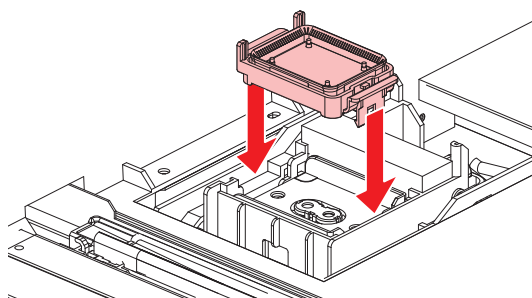
**7 Once replacement is complete, close the cover, then press the [ENTER] key.**

Replacing the Absorber Around the Station

If the cap absorber or maintenance liquid absorber is very dirty or if ink drips on to the media, replace with a new cap absorber.

1 On the LOCAL mode screen, select [MENU] > [Maintenance], then press the [ENTER] key.

- The Maintenance menu is displayed.

- 2 Select [Station Maint.] > [Carriage Out] > [Move To Platen Right End], then press the [ENTER] key.
 - The carriage moves over the platen.
- 3 Open the maintenance cover (right side).
- 4 Remove the cap absorber.

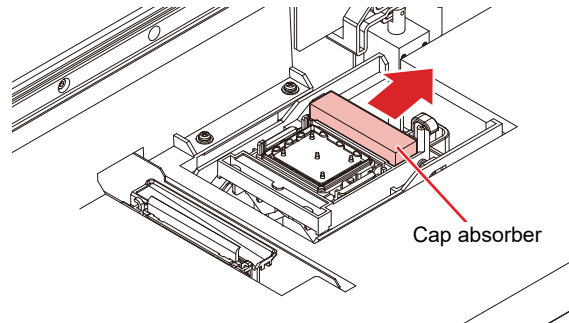

- Avoid ink dripping when removing the cap absorbers.

- 5 Clean the station cover.

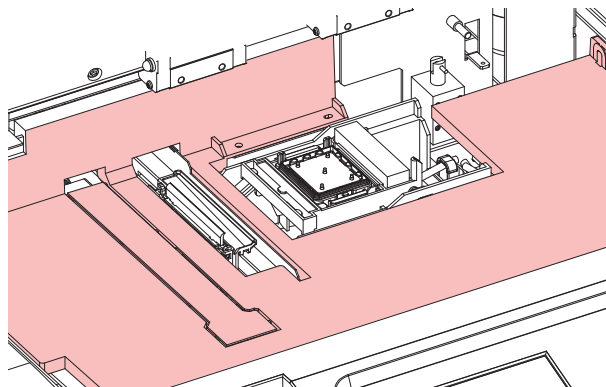

- For heavy soiling, wipe using a soft cloth soaked in diluted neutral detergent and thoroughly wrung out.

- 6 Mount a new cap absorber.



- As shown in the figure, mount the absorber with the narrow side on top and the wide side at the bottom.

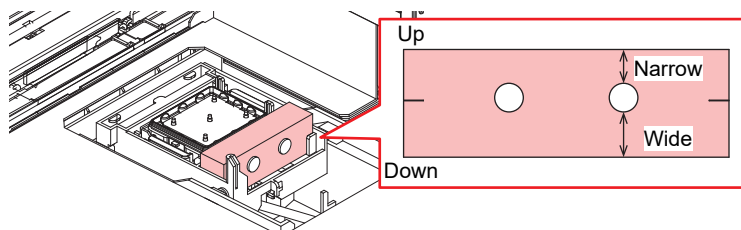

- 7 Once replacement is complete, close the cover, then press the [ENTER] key.

Pinch Roller Replacement

Replace worn or dirty pinch rollers with new ones.



- Turn off the main power and unplug the power cable before replacement.

- 1 Raise the clamp lever.
- 2 Remove the O-ring retaining the pinch rollers.

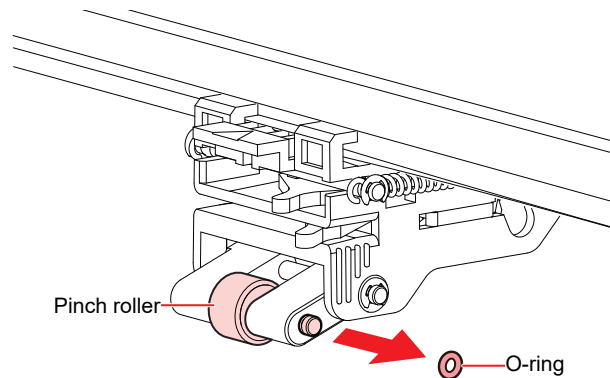

- The pinch rollers are small. Be careful to avoid dropping them into the product interior.

- 3 Remove the pinch roller spindle.

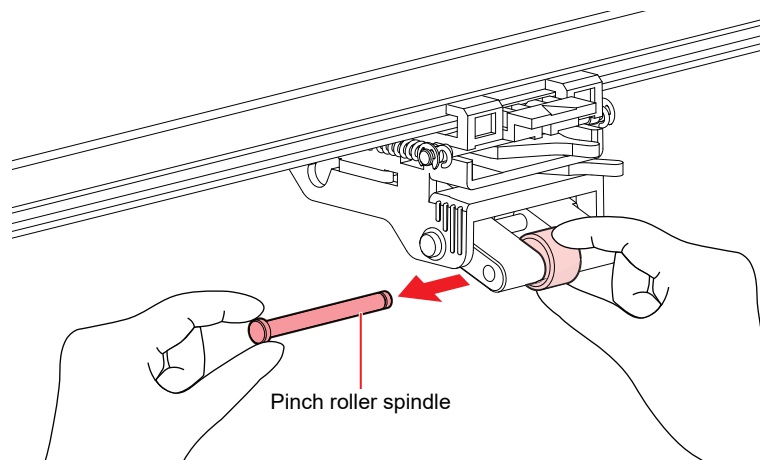

- 4 Mount new pinch rollers, and secure them using the O-ring.

Media Holder Replacement

If the media holder becomes deformed and touches the carriage or print head, replace with a new media holder.

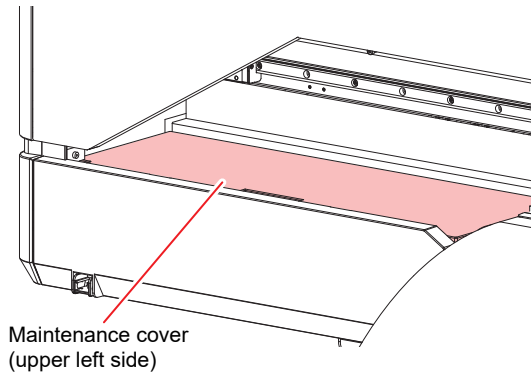
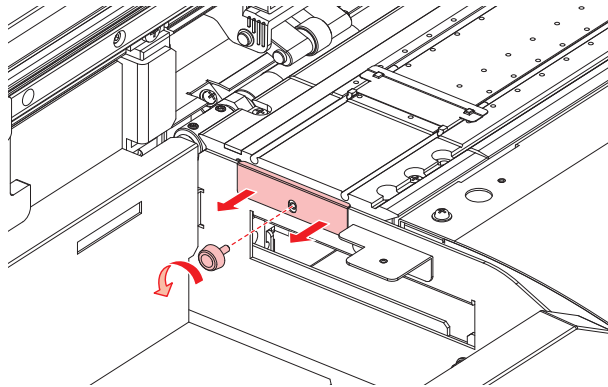
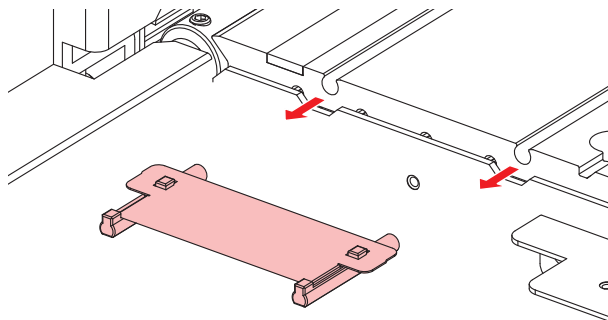
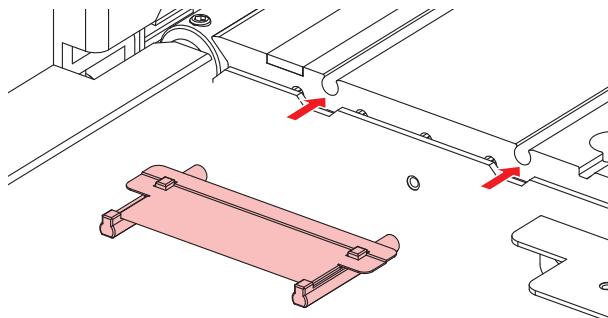

- Turn off the main power and unplug the power cable before replacement.

1 Remove the maintenance cover (upper left side).**2** Remove the side screw, and detach the media holder stopper.**3** Remove the media holder.**4** Mount the new media holder on to the platen.

5 Secure the media holder stopper with the screw.

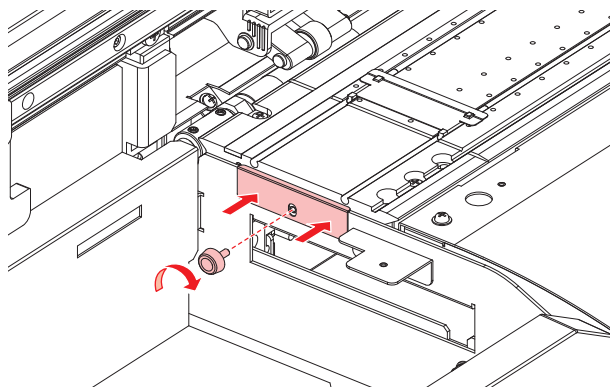

6 Attach the maintenance cover (upper left side).

Media Cutter Replacement

Replace cutters when blades are chipped or blunt.



- Avoid touching the cutter blade. Failure to do so may result in injury.

1 On the LOCAL mode screen, select [MENU] > [Maintenance], then press the [ENTER] key.

- The Maintenance menu is displayed.

2 Select [Station Maint.] > [Carriage Out] > [Move To Platen Right End], then press the [ENTER] key.

- The carriage moves over the platen.



- The carriage can be moved by hand. Move the carriage slowly to a position allowing easy access while working.

3 Replace the media cutter.

- (1) Unscrew the cutter screw.

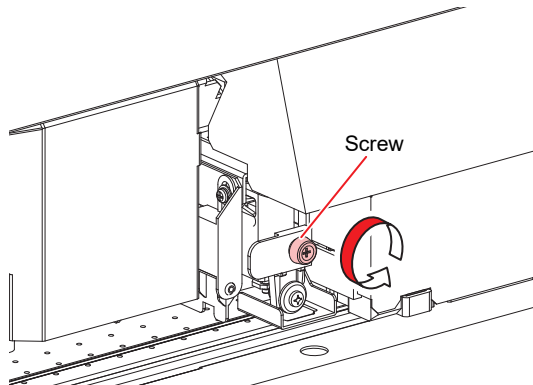

- (2) Remove the cutter.

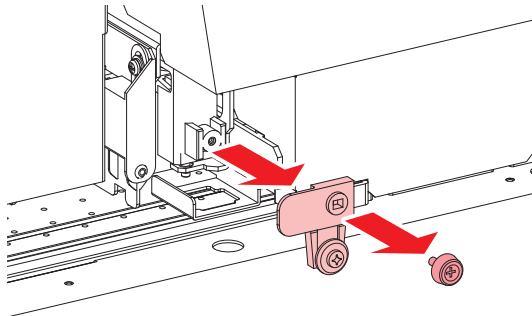

- (3) Mount a new cutter.
- (4) Tighten the screw to clamp the cutter.

4 Check the position of the media cutter.

- Lift up the media cutter by hand if it has dropped down.

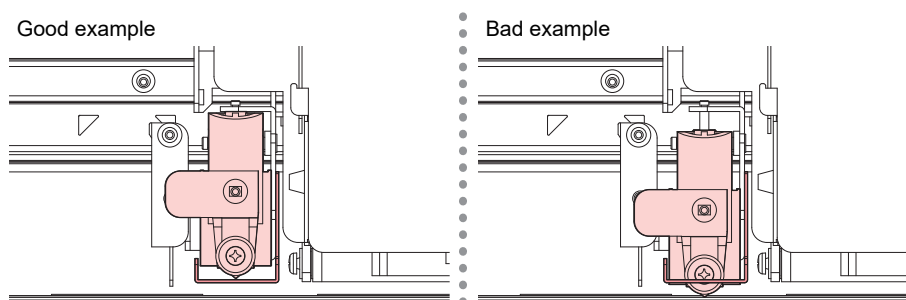

5 Press the [ENTER] key once replace is complete.

Waste Ink Tank Replacement

Ink used during head cleaning and other processes is collected in the waste ink tank at the lower right of the machine.

This product keeps track of the waste ink level. A "Check Waste Ink Tank" message appears when the preset level is reached. Use this a guide for replacing the waste ink tank.





- For a 2-liter tank, the preset level is 80 % (1.6 L).
- Continuing to use the product without disposing of the waste ink may result in waste ink overflowing from the waste ink tank. Visually check ink levels in the waste ink tank about once a week.



- Pay close attention to ventilation and be sure to wear safety glasses, gloves, and a mask when handling ink, maintenance liquid, waste ink, or other solutions used with the machine. Leaking ink may adhere to the skin or get into the eyes or mouth.



When "Check Waste Ink Tank" message appears

- 1** The "Check Waste Ink Tank" message appears on the display.
- 2** Check the waste ink levels in the waste ink tank.
 - If you note any discrepancies from actual levels, proceed to the next step.
 - If there is no discrepancy, replace (dispose of) the waste ink tank referring to  ["Replacing the Waste Ink Tank"\(P. 152\)](#).
- 3** On the LOCAL mode screen, select [MENU] > [Maintenance], then press the [ENTER] key.
 - The Maintenance menu is displayed.
- 4** Select [Waste Ink Tank], then press the [ENTER] key.
 - "Replace Wasteinktank Level: 80 % (1.6 L)" appears on the display.
- 5** Select [Adjust Waste Ink Volume], then press the [ENTER] key.
- 6** Press   to adjust the level.
- 7** Press the [ENTER] key once adjustment is complete.

Replacing the Waste Ink Tank

- 1** On the LOCAL mode screen, select [MENU] > [Maintenance], then press the [ENTER] key.
 - The Maintenance menu is displayed.
- 2** Select [Waste Ink Tank], then press the [ENTER] key.
 - "Replace Wasteinktank Level: 80 % (1.6 L)" appears on the display.
- 3** Select [Reset Waste Ink Volume], then press the [ENTER] key.

4 Pull the waste ink tank stopper forward.

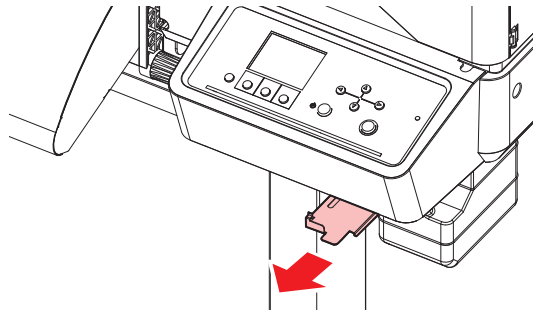

5 Hold the handle on the waste ink tank and slide out.

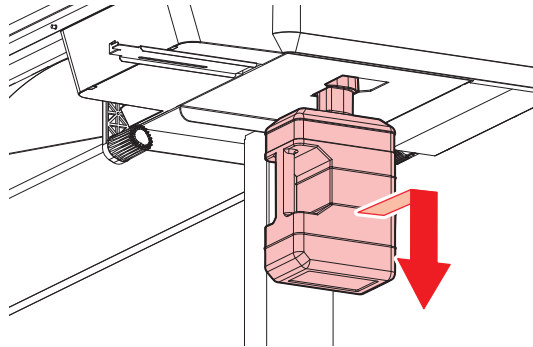

6 Attach the cap to the removed waste ink tank, and use tape to prevent leakage of waste ink.

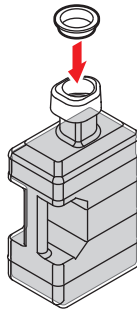

- When disposing of ink, maintenance liquid or other liquid used with the product, or containers or non-woven fabric contaminated with ink or other liquid, contact an industrial waste disposal operator or dispose of the product in accordance with the local laws and regulations.

7 Mount a new waste ink tank.

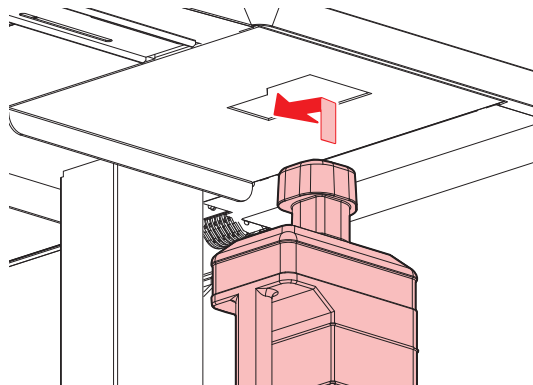

8 Close the waste ink tank stopper.

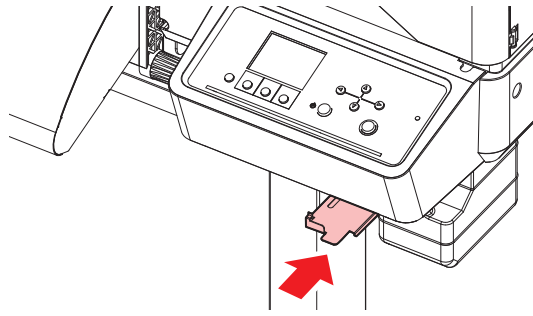

9 Press the [ENTER] key.

- The waste ink level will be reset.

Cutter for Cutting Machine

Replace cutters when blades are chipped or blunt.



- Avoid touching the cutter blade. Failure to do so may result in injury.
- Do not shake the cutter holder. The cutter blade may come out.

● Replacing Cutters

Installing Cutting Tools

Pen Line Replacement

This machine can be used with the following pen lines.

- Pen line rubber
Used for pen writing or cutting
- Pen line sponge
Used for half cut (cutting across a dotted line)



- Turn off the main power and unplug the power cable before replacement.

1 Use tweezers to peel off the end of the pen line.

- Wipe off any adhesive remaining in the platen slot with industrial alcohol.

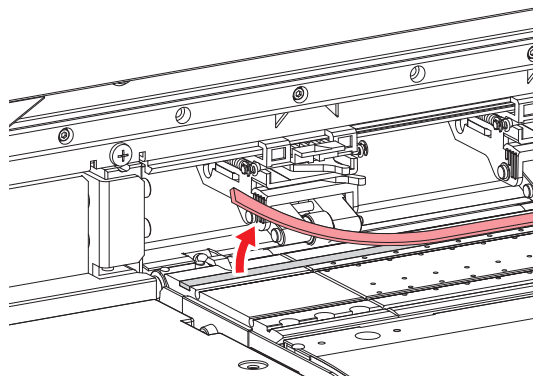

- 2 Attach double-sided tape in the platen slot.**
 - Peel off the base paper from the double-sided tape.
- 3 Attach the pen line on the double-sided tape.**
 - Make sure the pen line lies flat.

Chapter 7 Troubleshooting



This chapter

This chapter describes corrective actions for troubleshooting and messages on the display.





Troubleshooting.....	158	The ink has leaked out.....	162
The power does not turn on.....	158	Cutting Related	162
Printing is not possible.....	158	Problems Causing Messages to Appear	167
The media jams or the media is dirty.....	158	Warning Messages	167
Image defects occur.....	159	Ink error.....	168
The heater temperature does not rise to the specified value.	161	Error Message	169
		SYSTEM HALT	176

7.1 Troubleshooting





For information on troubleshooting, refer to this chapter. Refer to our website (<https://mimaki.com/support/>) for frequently asked questions (FAQs) about this product and customer support videos.

If the recommended corrective action does not resolve the problem, contact your local dealer or our service office.

The power does not turn on.

Points to check	Corrective action
Is the machine connected to the power outlet by the power cable?	Connect the power plug securely to the power outlet.  "Connecting the Power Cable"(P. 31)
Are you using the power cable provided?	Use the power cable provided.
Is the main power supply turned on?	Turn on the main power supply.   "Turning On the Power"(P. 31)
Is the [END/POWER] key on the operating panel turned on?	Turn the power on.  "Turning On the Power"(P. 31)

Printing is not possible.

Points to check	Corrective action
Is a USB interface cable connected?	Connect the cable securely to the USB 2.0 port.  "Using a USB Cable"(P. 34)
Is a LAN cable connected?	Connect the cable securely to the LAN port.  "Using a LAN Cable"(P. 33)
Are you using a LAN cable approved by Mimaki?	Check the LAN cable type.  "Using a LAN Cable"(P. 33)
Is the status lamp on the operating panel illuminated or flashing red?	An error has occurred. Check the message on the display.  "Operating Panel"(P. 28)

The media jams or the media is dirty.

Points to check	Corrective action
Are you using the recommended media?	Make sure you are using the recommended media. https://mimaki.com/supply/inkjet.html
Are you using curled media?	Do not use curled media or media with folded ends.
Is the media skewed?	Use the take-up unit to adjust the media or reload the media.  "Loading the Media"(P. 50)

Points to check	Corrective action
Does the media have ripples/surface irregularities or lift up?	<p>If you are using roll media, use a smooth section of the media for initial feeding. You can also improve this problem by attaching the NITOFロン[®] tape provided on the platen.</p>  <p>Be careful not to cover the vacuum holes.</p> <p>For more information, refer to the description on transporting media on the platen. https://mimaki.com/download/inkjet.html</p>

Image defects occur.

Symptom	Corrective action
White streaks, blurriness, and dark streaks ^{*1} occur. (Carriage scan direction)	<ol style="list-style-type: none"> 1. Remove any paper scraps or other debris adhering to areas over which the head passes (e.g., media holders). ☞ "Media Holder Cleaning"(P. 139) ☞ "Platen Cleaning"(P. 140) 2. Perform the procedure described in ☞ "Head Cleaning"(P. 69). 3. Perform the procedure described in ☞ "Feed Correction"(P. 71). 4. Perform the procedure described in ☞ "Cap Rubber Cleaning"(P. 130). 5. Perform the procedure described in ☞ "Carriage Underside Cleaning"(P. 131).
Text is double- or triple-printed in the media feed direction.	<ol style="list-style-type: none"> 1. Perform the procedure described in ☞ "Feed Correction"(P. 71).
Offsetting occurs during bidirectional printing.	<ol style="list-style-type: none"> 1. Perform the procedure described in ☞ "Correcting the Drop Position"(P. 73).
Ink droplets drip during printing.	<ol style="list-style-type: none"> 1. Perform the procedure described in ☞ "Cap Rubber Cleaning"(P. 130). 2. Perform the procedure described in ☞ "Carriage Underside Cleaning"(P. 131). 3. Perform the procedure described in ☞ "Head Cleaning"(P. 69). 4. Set auto maintenance. ☞ "Maintenance Menu"(P. 113)
Nozzles are clogged.	<ol style="list-style-type: none"> 1. Perform the procedure described in ☞ "Head Cleaning"(P. 69). 2. Perform the procedure described in ☞ "Print Head Nozzle Washing"(P. 161). 3. Perform the procedure described in ☞ "Registering Nozzle Recovery Manually"(P. 115).
Are the print heads too high?	Adjust the print head height. ☞ "Adjusting Print Head Height"(P. 45) If the print heads cannot be lowered, increase the refresh level during printing (☞ P. 113) or perform regular test printing to check for nozzle clogging.
Are there any ink colors that aren't used much?	Discharge from infrequently used nozzles tends not to be consistent. Although increasing the refresh level during printing (Maintenance Menu) will enable more frequent nozzle use, note that this will also increase ink consumption.
Are you using media easily affected by static electricity?	Increase the refresh level during printing (☞ P. 113) or perform regular test printing to check for nozzle clogging.

Symptom	Corrective action
Is the machine installed in a location with low humidity?	Increase the humidity by installing a humidifier or similar equipment. When printing continuously, also increase the refresh level during printing (☞ P. 113) or perform regular test printing to check for nozzle clogging.
Is the machine installed in a location where dust or powder is present?	Install the machine in a location free of dust or powder (office equivalent: dust level 0.15 mg/m ³).

*1. Even if test printing is OK, horizontal streaks may appear on the solid color print when the resolution is set to 900 × 600dpi and the scan speed is set to "Hi".

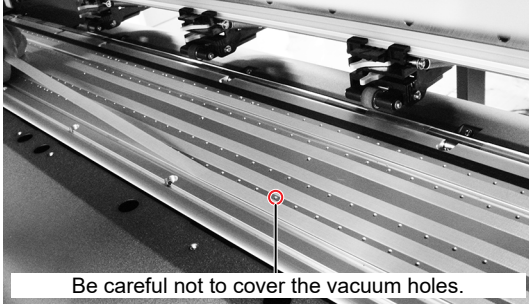
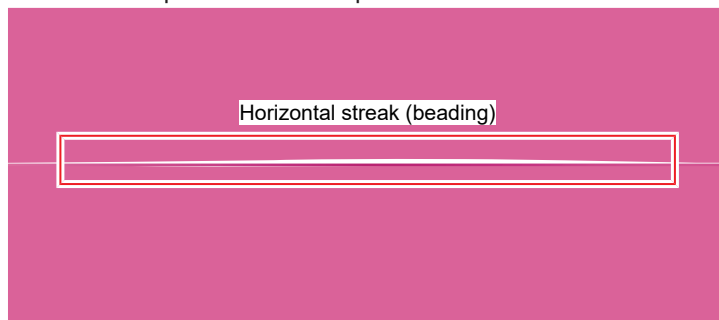

If horizontal streaks reappear even after the corrective actions in the table are taken, check the following settings and change the print conditions.

- Use the profile suitable for the media.
- Increase the heater temperature. ☞ "Setting the Heater Temperature"(P. 66)
- Increase the number of passes.

Print Head Nozzle Washing

If ejection failures (e.g., nozzle clogging or deflection) remain unresolved even after head cleaning (Head Cleaning), apply nozzle wash to the print head.

- 1** On the LOCAL mode screen, select [MENU] > [Maintenance], then press the [ENTER] key.
 - The Maintenance menu is displayed.
- 2** Select [Station Maint.] > [Nozzle Wash], then press the [ENTER] key.
 - The carriage moves over the platen.
- 3** Open the maintenance cover on the right side.
- 4** Clean the cap rubber.
 - Cap Rubber Cleaning
- 5** Once cleaning is complete, close the cover, then press the [ENTER] key.
- 6** Open the maintenance cover on the right side.
- 7** Fill the cap with maintenance liquid.



- Use a syringe to draw up some maintenance liquid and fill until it almost overflows from the cap.

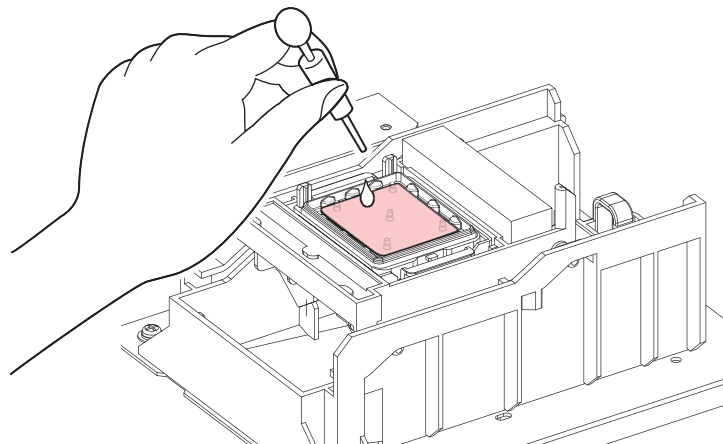



- 8** Close the maintenance covers.
- 9** Set the exposure time, then press the [ENTER] key.
 - Cleaning is performed automatically once print nozzle washing has ended.



- If ejection failures (e.g., nozzle clogging or deflection) remain unresolved even after washing the nozzles several times, contact your local dealer or our service office.

The heater temperature does not rise to the specified value.

This may indicate a problem with the setting.



Points to check	Corrective action
Is the 100V/200V selector switch set correctly?	Set the selector switch according to the power supply voltage. For the switch position, contact our service office.
Is the heater temperature set?	Set the heater temperature.  "Setting the Heater Temperature"(P. 66)  "Media Setting Menu"(P. 110)

The ink has leaked out



- If an ink leak occurs, turn off the main power immediately and unplug the power cable. Then, contact your local dealer or our service office.

Cutting Related

Symptom	Corrective action
The cut position shifts.	This may indicate a problem with the register mark sensor. Perform the operation used to check the responsiveness of the register mark sensor. You cannot check the responsiveness of the register mark sensor manually.  "Adjusting the Position of the Register Mark Sensor"(P. 162)
Cutting is not possible.	Cut a sample stored in the machine to identify the cause. Executing a sample cut will clear any data saved in the receive buffer.  "Investigating the Cause of Cutting Failures"(P. 164)
The print and cut positions are misaligned.	Use the MIMAKI RIP software (RasterLink) to print a correction pattern. Check the correction pattern and input correction values manually.  "Adjusting to Correct Misalignment Between Printing and Cutting"(P. 164)
The print and cut positions are misaligned in the scan direction.	Print the correction pattern to perform automatic correction. <ol style="list-style-type: none"> 1. Position the media. <ul style="list-style-type: none"> – Prepare white media used to print a correction pattern. 2. On the LOCAL mode screen, select [MENU] > [Cutting], then press the [ENTER] key. <ul style="list-style-type: none"> – The Cutting menu is displayed. 3. Select [Maintenance] > [Scale Adjust], then press the [ENTER] key. 4. When the confirmation screen is displayed, press the [ENTER] key. <ul style="list-style-type: none"> – Print the correction pattern to perform automatic correction.

Adjusting the Position of the Register Mark Sensor

- 1 Prepare the media on which register marks are printed.**
 - Creating Register Marks
- 2 On the LOCAL mode screen, select [MENU] > [Cutting], then press the [ENTER] key.**
 - The Cutting menu is displayed.
- 3 Select [Maintenance] > [Marks Sensor] > [Sensor Check], then press the [ENTER] key.**
 - The cutting unit moves over the platen.

4 Press \blacktriangle \blacktriangledown \blacktriangleleft \blacktriangleright to move the LED pointer.

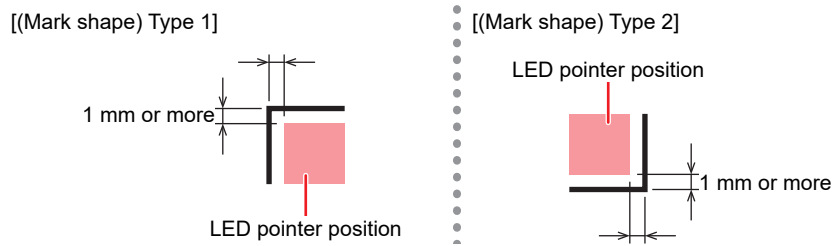

5 Register the information corresponding to the printed register mark conditions.

- Setting Mark Detection Conditions
- The set register mark conditions are also stored in [Cutting] > [Mark Detect]. The settings are retained even when the power is turned off.

6 Press [ENTER] to start the detection operation.

- The machine automatically detects the lines in the X and Y directions (automatic detection operation: plus X direction > minus X direction > plus Y direction > minus Y direction).

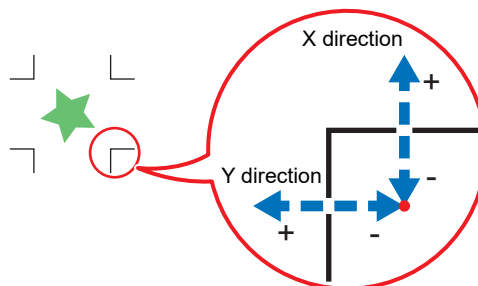

- A buzzer sounds each time a line is detected (four buzzers in all). If any of the buzzers fails to sound, refer to the following:
["Correcting the LED Pointer Position"\(P. 163\)](#)

Correcting the LED Pointer Position

If the register marks cannot be read properly, the register mark sensor may be misaligned. Refer to the following to correct the position of the register mark sensor:

- 1 Attach a pen to the tool holder.**
 - Using a Pen
- 2 Load copy paper.**
- 3 On the LOCAL mode screen, select [MENU] > [Cutting], then press the [ENTER] key.**
 - The Cutting menu is displayed.
- 4 Select [Maintenance] > [Marks Sensor] > [Pointer Offset], then press the [ENTER] key.**
 - A 10 mm cross pattern is drawn.
 - The LED pointer turns on and moves to the center of the cross pattern.
- 5 Press \blacktriangle \blacktriangledown \blacktriangleleft \blacktriangleright to move the LED pointer to the center of the cross pattern.**
- 6 Press the [ENTER] key to complete the settings.**
 - The settings are retained even if [Setup Reset] is selected.

7 Check the following again.

-  "Adjusting the Position of the Register Mark Sensor"(P. 162)
- If the buzzer does not sound four times, check the printed register mark conditions and contact your local distributor, our sales office, or service center.

Investigating the Cause of Cutting Failures

1 On the LOCAL mode screen, select [MENU] > [Cutting], then press the [ENTER] key.



- The Cutting menu is displayed.

2 Select [Maintenance] > [Sample Cut], then press the [ENTER] key.

3 Select the sample data, then press the [ENTER] key.

- There are two sample types: "Cut" and "Logo".



- If you select "Cut", press the [ENTER] key to start cutting.
- If you select "Logo", refer to the following:
 - (1) Press   to specify the scaling factor (1 to 999 %).
 - (2) Press the [ENTER] key to start cutting
 - The settings are retained even if [Setup Reset] is selected.

● Sample Cut Results

- Sample data can be cut properly, but not other data.
 - There is a problem with the host PC.
- Sample data as well as other data cannot be cut properly.
 - There is a problem with the printer. Increase the pressure in the Adj-prs Offset menu. Cutting Menu

Adjusting to Correct Misalignment Between Printing and Cutting

In the procedure described below, MIMAKI RIP software (RasterLink) is used to print a correction pattern. When printing and cutting, correction is required for each resolution in the scan (Y) direction. (The corrected value is saved for each resolution.) Print a pattern for each resolution, then input the correction value.

1 Switch the machine to REMOTE mode.

2 Set the print conditions (profile/cut conditions) for the job you want to print in RasterLink.

- Specify the following settings by clicking the function icons shown on the right-hand side of the screen:

 (General Print): Specifies settings like enlargement/reduction and rotation.

 (Quality): Selects a color profile for the media and ink set loaded in this machine.



- For more information, refer to the RasterLink reference guide. <https://mimaki.com/download/software.html>

- 3 Click  (General Print) and click on [Print & Cut origin adjust] on the [Cut Edit] tab.

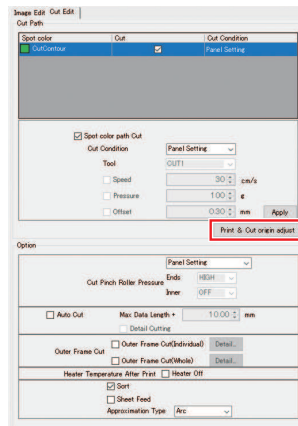

Important! • Note that **the input units vary** depending on whether or not register marks are used.

Without register marks

- 1 Click [OK] to print a correction pattern.

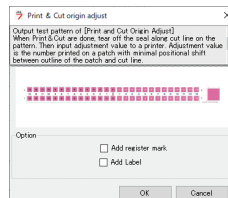

- 2 On the REMOTE mode screen, select [Adjust].

- 3 Select [PC Origin Offset], then press the [ENTER] key.

- A correction pattern is cut. Detach the cut part of the pattern and check the adjustment values.

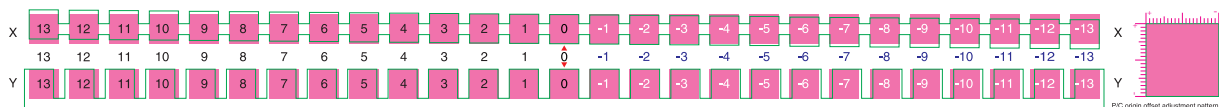

- 4 Input the numerical value of the position with the lowest vertical misalignment.

- In the illustration below, enter "-4".

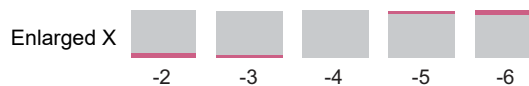

- 5 Input the numerical value of the position with the lowest horizontal misalignment.

- In the illustration below, enter "2".



With register marks

1 Select [Add register mark].

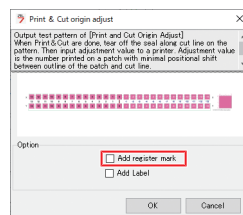

2 Click [OK] to print a correction pattern.

3 On the REMOTE mode screen, select [Adjust].

4 Select [TP Offset], then press the [ENTER] key.

- The register marks are detected, and a correction pattern is cut. Detach the cut part of the pattern and check the adjustment values.

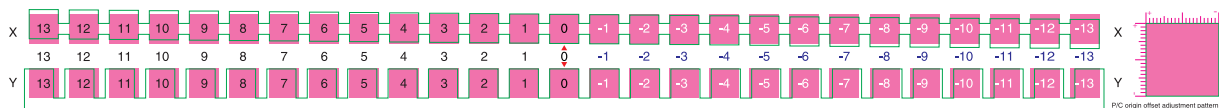

5 Input the numerical value of the position with the lowest vertical misalignment.

- In the illustration below, the value is "-4", so enter "-0.4 mm".

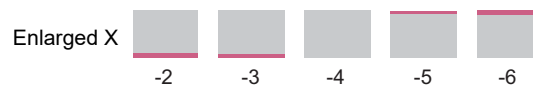

6 Input the numerical value of the position with the lowest horizontal misalignment.

- In the illustration below, the value is "2", so enter "0.2 mm".

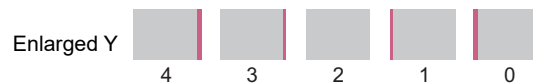









7.2 Problems Causing Messages to Appear

If a problem arises, the buzzer sounds and a message appears on the display.

You can also check the local guidance. Displaying Machine Information (Local Guidance)

Take the appropriate action in accordance with the content of the message. If a message reappears even after taking the prescribed action, contact your local dealer or our service office.

Warning Messages

Message	Cause	Corrective action
Replace NCU ^{*1} Ink Pad	<ul style="list-style-type: none"> The ink absorber needs to be replaced. 	<ul style="list-style-type: none"> The NCU^{*1} ink absorber must be replaced. Contact your local dealer or our service office.
Replace NCU ^{*1}	<ul style="list-style-type: none"> A problem was detected with the nozzle clogging assessment. 	<ul style="list-style-type: none"> Clean the NCU^{*1}  "Cleaning the NCU (Option)"(P. 134) Replace the NCU^{*1} if the error does not clear. Contact your local dealer or our service office.
NCU ^{*1} Sensor Lv Low	<ul style="list-style-type: none"> The sensor's sensitivity is impaired. 	<ul style="list-style-type: none"> Clean the NCU^{*1}  "Cleaning the NCU (Option)"(P. 134) Replace the NCU^{*1} if the error does not clear. Contact your local dealer or our service office.
NCU ^{*1} Sens Adj Err H	<ul style="list-style-type: none"> Sensor sensitivity adjustment failed. 	
NCU ^{*1} Sens Adj Err L		
NCU ^{*1} Connect	<ul style="list-style-type: none"> A problem was detected with the NCU^{*1} connection. 	<ul style="list-style-type: none"> Turn off the main power and wait a while before turning back on.
Ink Error	<ul style="list-style-type: none"> An ink error occurred. 	<ul style="list-style-type: none"> Check the ink error details.  "Ink error"(P. 168)
COVER OPEN	<ul style="list-style-type: none"> The cover is open. 	<ul style="list-style-type: none"> Close the cover.
Lower the clamp lever	<ul style="list-style-type: none"> The clamp lever is raised. 	<ul style="list-style-type: none"> Lower the clamp lever.  "Front"(P. 22)
Data Remain	<ul style="list-style-type: none"> Print (RIP) data was received. 	<ul style="list-style-type: none"> Switch to REMOTE mode and start printing or clear the data and abort printing.
Temporary Suspension	<ul style="list-style-type: none"> Printing has been paused. 	<ul style="list-style-type: none"> Switch to REMOTE mode and resume printing or clear the data and abort printing.
Printing not possible/ink IC	<ul style="list-style-type: none"> An unusable ink IC chip is used. 	<ul style="list-style-type: none"> Replace with new ink and a new ink IC chip.  "Replacing Ink"(P. 39)
No Media	<ul style="list-style-type: none"> No media is loaded, or the sensors are faulty. 	<ul style="list-style-type: none"> Load the media.  "Loading the Media"(P. 50) Clean the media sensor.  "Media Sensor Cleaning"(P. 137)
Please load media	<ul style="list-style-type: none"> No media is loaded, or the sensors are faulty. 	<ul style="list-style-type: none"> Load the media.  "Loading the Media"(P. 50)

Message	Cause	Corrective action
Media Undetected	<ul style="list-style-type: none"> The media width has not been detected. 	<ul style="list-style-type: none"> Detect the media width. "Loading the Media"(P. 50)
Wiper Move Failure	<ul style="list-style-type: none"> The wiper is not operating correctly. 	<ul style="list-style-type: none"> Turn off the main power and wait a while before turning back on.
Replace Wasteinktank	<ul style="list-style-type: none"> The waste ink tank count exceeded the preset value (90%). 	<p>Automatic maintenance is not possible while the covers are open. Perform the following steps:</p> <ol style="list-style-type: none"> Check the waste ink levels in the waste ink tank. "When "Check Waste Ink Tank" message appears"(P. 152) Replace the waste ink tank, then reset the waste ink level. "Replacing the Waste Ink Tank"(P. 152)
Check Waste Ink tank	<ul style="list-style-type: none"> The waste ink tank count exceeded the preset value (80%). 	<ol style="list-style-type: none"> Check the waste ink levels in the waste ink tank. "When "Check Waste Ink Tank" message appears"(P. 152) Replace the waste ink tank, then reset the waste ink level. "Replacing the Waste Ink Tank"(P. 152)
High ambient temp ** ° C	<ul style="list-style-type: none"> Ambient temperatures are too high. 	<ul style="list-style-type: none"> Adjust ambient temperatures to temperatures within the specified range. Optimum print quality may not be possible unless ambient conditions are within the specified range. "Installation Precautions"(P. 15)
Low ambient temp ** ° C	<ul style="list-style-type: none"> Ambient temperatures are too low. 	
Auto-correction failed	<ul style="list-style-type: none"> White media is not used. The media is dirty. The media lifts up. There is dirt around the sensor. 	<ul style="list-style-type: none"> Load white and clean media. Load media so it does not lift up. Clean the area around the sensor. "DAS (Automatic Correction Function) Sensor Cleaning"(P. 135) If automatic correction fails repeatedly, correct the position manually. "Feed Correction"(P. 71) "Correcting the Drop Position"(P. 73)

*1 NCU is optional.



Ink error











Message	Cause	Corrective action
Ink End	<ul style="list-style-type: none"> The ink has run out. 	<ul style="list-style-type: none"> Replace with new ink. "When Ink End is Displayed"(P. 38) If you use UISS, you may perform cleaning.
Ink Near End	<ul style="list-style-type: none"> Ink levels are low. 	<ul style="list-style-type: none"> The ink will run out soon. Have new ink ready. "When Ink Near End is Displayed"(P. 38)
Non Ink IC	<ul style="list-style-type: none"> No ink IC chip was detected. 	<ol style="list-style-type: none"> Insert the ink IC chip. "Replacing Ink"(P. 39) Check to confirm the ink IC chip was inserted correctly. "Replacing Ink"(P. 39)

Message	Cause	Corrective action
		3. Turn off the main power and wait a while before turning back on.
Wrong Ink IC	<ul style="list-style-type: none"> An error occurred with the information on the ink IC chip. 	<ol style="list-style-type: none"> Check to confirm the ink IC chip was inserted correctly. "Replacing Ink"(P. 39) Turn off the main power and wait a while before turning back on. Replace with new ink. "Replacing Ink"(P. 39)
Ink Color	<ul style="list-style-type: none"> The ink color registered on the IC chip is different from the ink color filled. 	<ul style="list-style-type: none"> Insert an ink IC chip for the correct ink color. "Replacing Ink"(P. 39)
Ink Type	<ul style="list-style-type: none"> The ink type registered on the IC chip is different from the ink type filled. 	<ul style="list-style-type: none"> Insert an ink IC chip for the correct ink type. "Replacing Ink"(P. 39)
Expiration Near	<ul style="list-style-type: none"> The ink has expired. 	<ul style="list-style-type: none"> Replace with new ink or use up as quickly as possible. Printing is possible. "When Ink End is Displayed"(P. 38)
Expiration Over	<ul style="list-style-type: none"> The ink is two months past its expiration date and cannot be used. 	<ul style="list-style-type: none"> Replace with new ink. Printing is not possible. "When Ink End is Displayed"(P. 38)

Error Message





Error number	Message	Cause	Corrective action
04	PARAM ROM	<ul style="list-style-type: none"> A problem was detected with the main PCB. 	<ul style="list-style-type: none"> Turn off the main power and wait a while before turning back on. "Turning Off the Power"(P. 32)
108	HD THERMIS[1]	<ul style="list-style-type: none"> A problem was detected with print head temperature control. 	
108	HD CONNECT[1]	<ul style="list-style-type: none"> A problem was detected with the print head connection. 	
108	HD MEM EMP[1]	<ul style="list-style-type: none"> A problem was detected with the print head. 	
10e	FROM CLEAR	<ul style="list-style-type: none"> A problem was detected with the main PCB. 	
10f	FROM WRITE		
122	CHECK:SDRAM	<ul style="list-style-type: none"> A problem was detected with the SDRAM. 	
123	PRAM DATA	<ul style="list-style-type: none"> A problem was detected with the main PCB. 	
124	PRAM ADDR		
127	POWER OFF		
128	HDC FIFO OVER	<ul style="list-style-type: none"> A problem was detected with the print head control PCB. 	
128	HDC FIFO UNDER		





Error number	Message	Cause	Corrective action
129	Battery Exchange	<ul style="list-style-type: none"> The internal clock battery is spent and must be replaced. 	<ul style="list-style-type: none"> Contact your local dealer or our service office.
12a	HDC SPEED	<ul style="list-style-type: none"> A problem was detected with the print head control. 	<ul style="list-style-type: none"> Turn off the main power and wait a while before turning back on.  "Turning Off the Power"(P. 32)
130	HD DATA SEQ	<ul style="list-style-type: none"> A problem was detected with the print head control. 	
147	DS-IC BUSY	<ul style="list-style-type: none"> Ink IC control abnormality detected. 	
148	E-LOG SEQ	<ul style="list-style-type: none"> A log control abnormality was detected. 	
154	Main PCB V05	<ul style="list-style-type: none"> A problem was detected with the main PCB 5V power supply. 	
155	Main PCB V42-1	<ul style="list-style-type: none"> A problem was detected with the main PCB 42V power supply. 	
171	NEW HEAD CONNECT	<ul style="list-style-type: none"> A new print head connection was detected. 	
186	HDC OVERFLOW/HDC UNDERFLOW	<ul style="list-style-type: none"> A problem was detected with the print head control. 	
187	HDC SLEW RATE		
188	HDC MEMORY		
18e	FLS NOT COMP		
18f	OFFSET START [1]	<ul style="list-style-type: none"> A problem was detected with the print head control. 	
18f	OFFSET END [1]		
1b8	HEAD XHOT		
201	Command Error	<ul style="list-style-type: none"> Data other than print (RIP) data was received, or a problem was detected with the print (RIP) data received. 	<ol style="list-style-type: none"> Clear the data and resend. Check the USB/Ether cable connection. Connecting a PC to the Product Use a compatible cable. Connecting a PC to the Product Turn off the main power and wait a while before turning back on.
202	Parameter Error	<ul style="list-style-type: none"> A problem was detected with the print (RIP) data received. 	
206	Print Mode Error	<ul style="list-style-type: none"> Print (RIP) data was received with print parameters that do not allow printing. 	<ul style="list-style-type: none"> Change the output parameters and profile using RIP software.
20A	Driver Version	<ul style="list-style-type: none"> Printing is not possible because the Mimaki driver version is old. 	<ul style="list-style-type: none"> Install the latest Mimaki driver available from: https://mimaki.com/download/inkjet.html
303	PCB MAIN ET	<ul style="list-style-type: none"> A problem was detected with the main PCB. 	<ol style="list-style-type: none"> Turn off the main power and wait a while before turning back on.  "Turning Off the Power"(P. 32)

Error number	Message	Cause	Corrective action
304	USB INIT ERR	<ul style="list-style-type: none"> A problem was detected with the USB cable connection. 	1. Check the USB cable connection.  "Using a USB Cable"(P. 34)
305	USB TIME OUT		2. Use a compatible cable.  "Using a USB Cable"(P. 34) 3. Turn off the main power and wait a while before turning back on.  "Turning Off the Power"(P. 32)
401	Motor X	<ul style="list-style-type: none"> The X motor was overloaded. 	1. Check to confirm the media is loaded correctly.  "Loading the Media"(P. 50) 2. Check for anything that may obstruct carriage movement. 3. Turn off the main power and wait a while before turning back on.  "Turning Off the Power"(P. 32)
402	Motor Y	<ul style="list-style-type: none"> The Y motor was overloaded. 	
403	X Current	<ul style="list-style-type: none"> An overcurrent error was detected in the X motor. 	
404	Y Current	<ul style="list-style-type: none"> An overcurrent error was detected in the Y motor. 	
406	Wiper Move Failure	<ul style="list-style-type: none"> The wiper origin could not be detected. 	<ul style="list-style-type: none"> Turn off the main power and wait a while before turning back on.  "Turning Off the Power"(P. 32)
44f	Take-up Roll Sns Err	<ul style="list-style-type: none"> A problem was detected with the take-up unit sensor spindle. 	1. Check to confirm the [Function Setting] > [Take-up Unit] setting is "ON". 2. Check to confirm the media is loaded correctly.  "Loading the Roll Media"(P. 55) 3. Check to confirm the take-up unit switch functions properly.  "Take-up unit"(P. 51)
45a	Failed Cutter unit joint	<ul style="list-style-type: none"> The carriage could not be disconnected. 	<ul style="list-style-type: none"> Turn off the main power and wait a while before turning back on.  "Turning Off the Power"(P. 32)
45b	Failed Cutter unit detach	<ul style="list-style-type: none"> Unable to connect to carriage 	
45e	Check PR/GR Position	<ul style="list-style-type: none"> A problem was detected with the pinch roller positions. 	<ul style="list-style-type: none"> Place the pinch rollers above the grit rollers.
47f	Take-up Diameter Max	<ul style="list-style-type: none"> The take-up unit media diameter has reached the maximum value. 	1. Replace the paper core in the take-up unit.
48a	Detect winding failure	<ul style="list-style-type: none"> A problem was detected with the take-up unit. 	1. Check to confirm the [Function Setting] > [Take-up Unit] setting is "ON". 2. Check to confirm the media is loaded correctly.  "Loading the Roll Media"(P. 55) 3. Check to confirm the take-up unit switch functions properly.  "Take-up unit"(P. 51)
504	CLAMP UP	<ul style="list-style-type: none"> The clamp lever is lifted. 	<ul style="list-style-type: none"> Lower the clamp lever.
505	Media Jam	<ul style="list-style-type: none"> The media jam sensor was triggered. 	1. Remove the media in contact with the carriage and reload with fresh media.  "Loading the Media"(P. 50) 2. Check for anything that may obstruct carriage movement.

Error number	Message	Cause	Corrective action
509	HDC POSCNT	<ul style="list-style-type: none"> A problem was detected with position control. 	<ul style="list-style-type: none"> Turn off the main power and wait a while before turning back on. "Turning Off the Power"(P. 32)
50a	Y Org Detect Error	<ul style="list-style-type: none"> A problem was detected with Y origin detection (initialization). 	
50c	Check Media With Sensor	<ul style="list-style-type: none"> A problem was detected with media width detection. 	<ol style="list-style-type: none"> Check the media loading position. "Loading the Media"(P. 50) Clean the media width sensor. "DAS (Automatic Correction Function) Sensor Cleaning"(P. 135)
50f	L-SCALE BLACK	<ul style="list-style-type: none"> A problem was detected with the linear scale. 	<ul style="list-style-type: none"> Turn off the main power and wait a while before turning back on. "Turning Off the Power"(P. 32)
516	Media Set Position R (L)	<ul style="list-style-type: none"> The media was loaded outside the range of valid positions. 	<ol style="list-style-type: none"> Check the media loading position. "Loading the Media"(P. 50) Clean the media width sensor. "Media Sensor Cleaning"(P. 137)
523	Check PR Sensor	<ul style="list-style-type: none"> The pinch roller position detection failed. 	<ul style="list-style-type: none"> Turn off the main power and wait a while before turning back on. "Turning Off the Power"(P. 32)
54b	Media Press	<ul style="list-style-type: none"> Media retainer detection failed. 	<ol style="list-style-type: none"> Check the media loading position. "Loading the Media"(P. 50) Clean the media width sensor. "Media Sensor Cleaning"(P. 137)
54c	Vacuum Fan Err	<ul style="list-style-type: none"> A problem was detected with the vacuum fan. 	<ul style="list-style-type: none"> Turn off the main power and wait a while before turning back on. "Turning Off the Power"(P. 32)
602	Ink End	<ul style="list-style-type: none"> The ink has run out. 	<ul style="list-style-type: none"> Replace with new ink. "When Ink End is Displayed"(P. 38)
604	Check Waste Ink tank	<ul style="list-style-type: none"> The waste ink tank count exceeded the preset value (80%). 	<ol style="list-style-type: none"> Check the waste ink levels in the waste ink tank. "When "Check Waste Ink Tank" message appears"(P. 152) Replace the waste ink tank, then reset the waste ink level. "Replacing the Waste Ink Tank"(P. 152)
605	Replace Wiper	The wiper needs to be replaced.	<ol style="list-style-type: none"> Perform [Maintenance] > [Station Maint.] > [Replace Wiper], then replace the wiper (the wiper usage count will be reset).
608	Wrong Ink IC	<ul style="list-style-type: none"> An error occurred with the information on the ink IC chip. 	<ol style="list-style-type: none"> Check to confirm the ink IC chip was inserted correctly. "Replacing Ink"(P. 39) Turn off the main power and wait a while before turning back on. "Turning Off the Power"(P. 32) Replace with new ink. "Replacing Ink"(P. 39)
60a	Excess Ink Usage	<ul style="list-style-type: none"> The ink usage amount stored in the ink IC chip exceeded the preset value. 	<ul style="list-style-type: none"> Replace with new ink. "When Ink End is Displayed"(P. 38)

Error number	Message	Cause	Corrective action
		<ul style="list-style-type: none"> The ink IC chip was not replaced during ink replacement. (The same chip continued to be used.) The machine was used with nozzle clogging. 	
60c	Ink Type	<ul style="list-style-type: none"> The ink type registered on the IC chip is different from the ink type filled. 	<ul style="list-style-type: none"> Insert an ink IC chip for the correct ink type. "Replacing Ink"(P. 39)
627	Set Eco-cases	<ul style="list-style-type: none"> The ink IC chip could not be read for a certain period of time. 	<ol style="list-style-type: none"> Check to confirm the ink IC chip was inserted correctly. Turn off the main power and wait a while before turning back on. "Turning Off the Power"(P. 32)
629	Expiration Near	<ul style="list-style-type: none"> The ink has expired. 	<ul style="list-style-type: none"> Replace with new ink or use up as quickly as possible. Printing is possible. "When Ink End is Displayed"(P. 38)
62a	Expiration Over	<ul style="list-style-type: none"> The ink is two months past its expiration date and cannot be used. 	<ul style="list-style-type: none"> Replace with new ink. Printing is not possible. "When Ink End is Displayed"(P. 38)
631	Ink Color	<ul style="list-style-type: none"> The ink color registered on the IC chip is different from the ink color filled. 	<ul style="list-style-type: none"> Insert an ink IC chip for the correct ink color. "Replacing Ink"(P. 39)
650	NCU ^{*1} Connect	<ul style="list-style-type: none"> A problem was detected with the NCU^{*1} connection. 	<ul style="list-style-type: none"> Turn off the main power and wait a while before turning back on. "Turning Off the Power"(P. 32)
651	Replace NCU ^{*1}	<ul style="list-style-type: none"> A problem was detected with the nozzle clogging assessment. 	<ul style="list-style-type: none"> Clean the NCU^{*1} "Cleaning the NCU (Option)"(P. 134) Replace the NCU if the error does not clear. Contact your local dealer or our service office.
652	NCU ^{*1} NzK Chk (Hw)	<ul style="list-style-type: none"> A problem was detected with the nozzle clogging assessment. 	<ul style="list-style-type: none"> Clean the NCU^{*1} "Cleaning the NCU (Option)"(P. 134)
653	NCU ^{*1} NzK Chk (Mark)		
654	NCU Center Pos		
655	NCU Flush Pos		
656	NCU ^{*1} SN Adjst		
657	Replace NCU ^{*1} Ink Pad	<ul style="list-style-type: none"> The NCU^{*1} ink absorber is full. 	<ul style="list-style-type: none"> The NCU^{*1} ink absorber must be replaced. Contact your local dealer or our service office.
658	NCU ^{*1} Sensor Lv Low	<ul style="list-style-type: none"> The sensor's sensitivity is impaired. 	<ul style="list-style-type: none"> Clean the NCU^{*1} "Cleaning the NCU (Option)"(P. 134) Replace the NCU (option) if the error does not clear. Contact your local dealer or our service office.
65b	NCU ^{*1} Sens Adj Err H	<ul style="list-style-type: none"> Sensor sensitivity adjustment failed. 	
65c	NCU ^{*1} Sens Adj Err L		

Error number	Message	Cause	Corrective action	
702	Thermistor Connect	<ul style="list-style-type: none"> A problem was detected with the thermistor connection. 	<ul style="list-style-type: none"> Turn off the main power and wait a while before turning back on.  "Turning Off the Power"(P. 32) 	
703	Heater Brk	<ul style="list-style-type: none"> A problem was detected with the heater temperature. 		
710	Heater Temp Error	<ul style="list-style-type: none"> A problem was detected with the heater temperature. 	<ul style="list-style-type: none"> This error will be automatically resolved. If the error is not resolved, turn off the main power and wait a while before turning back on. 	
801	(C) OP CODE	<ul style="list-style-type: none"> A problem was detected with the main PCB. 	<ul style="list-style-type: none"> Turn off the main power and wait a while before turning back on.  "Turning Off the Power"(P. 32) 	
802	(C) SWI			
803	(C)PFTCHABRT			
804	(C)DATAABRT			
806	FW/SIO bit	<ul style="list-style-type: none"> A communication error was detected between the boards. 		
808	FW/STP-MTR**	<ul style="list-style-type: none"> A problem was detected with the main PCB. 		
80f	FW/SIO Vch	<ul style="list-style-type: none"> A communication error was detected between the boards. 		
811	FW/SIO read	<ul style="list-style-type: none"> A communication error was detected between the boards. 		
81b	FW/STACK OV	<ul style="list-style-type: none"> A problem was detected with the main PCB. 		
828	PRG ERR L*****			
901	Operation Error	<ul style="list-style-type: none"> The function is disabled due to an error. 		<ul style="list-style-type: none"> Check the error details. <ul style="list-style-type: none"> Media Undetected Ink error Waste ink tank, etc.
902	Data Remain	<ul style="list-style-type: none"> Print (RIP) data was received. 		<ul style="list-style-type: none"> Switch to REMOTE mode and start printing or clear the data and abort printing.
90f	Print Area Short	<ul style="list-style-type: none"> The media is too small for the print. 	<ul style="list-style-type: none"> Replace with wider or longer media. If the printable area is reduced due to a shift in the origin, move the origin to increase the size of the printable area. 	
b49	PCB VHV FET[1]	<ul style="list-style-type: none"> A problem was detected with the PCB power supply. 	<ul style="list-style-type: none"> Turn off the main power and wait a while before turning back on.  "Turning Off the Power"(P. 32) 	
C10	Command	<ul style="list-style-type: none"> Received a code other than a COMMAND code. 	<ol style="list-style-type: none"> Clear the data and resend. Check the USB/Ether cable connection.  "Connecting a PC to the Product"(P. 33) 	

Error number	Message	Cause	Corrective action
C11	Parameter	<ul style="list-style-type: none"> Received parameter outside numerical value range 	<ol style="list-style-type: none"> Use a compatible cable.  "Connecting a PC to the Product"(P. 33) Turn off the main power and wait a while before turning back on.
C12	Device	<ul style="list-style-type: none"> Received an invalid device control command. 	
C31	No Data	<ul style="list-style-type: none"> "COPY" was executed, but no data is saved to the receive buffer. 	<ul style="list-style-type: none"> Transmit the same data once more.
C32	DataTooBig	<ul style="list-style-type: none"> The received data is too big for multiple sheet cutting. 	<ul style="list-style-type: none"> Change the data size.
C33	Sheet Size	<ul style="list-style-type: none"> The sheet is too short in the feed direction. 	<ul style="list-style-type: none"> Use a longer sheet.
C36	Mark Detect	<ul style="list-style-type: none"> Unable to detect register marks 	<ol style="list-style-type: none"> Check to confirm the register marks are placed properly.  "Register Marks"(P. 100) Load the uncurled media. Check the mark detection start position. Check to confirm the register marks are black and printed on a white background. Check to confirm the area between the register marks is clean and free of print. Check to confirm there are no errors in the mark detection settings. If the area around the register marks is filled in, set [Mark Detect] > [Mark FillUp] setting to "ON".
C37	Mark Org	<ul style="list-style-type: none"> The mark detection result shows that the register marks were detected outside the plotting range. 	<ul style="list-style-type: none"> Change the layout by referring to the following:  "Reading Range of Register Marks"(P. 103)
C38	Register mark scale	<ul style="list-style-type: none"> Unable to detect register marks 	<ol style="list-style-type: none"> Check to confirm the register marks are placed properly.  "Register Marks"(P. 100) Load the uncurled media. Check the mark detection start position. Check to confirm the register marks are black and printed on a white background. Check to confirm the area between the register marks is clean and free of print. Check to confirm there are no errors in the mark detection settings. If the area around the register marks is filled in, set [Mark Detect] > [Mark FillUp] setting to "ON".
C60	PenEncoder	<ul style="list-style-type: none"> Unable to detect pen height. 	<ul style="list-style-type: none"> Turn off the main power and wait a while before turning back on.  "Turning Off the Power"(P. 32)
C61	Pen Stroke	<ul style="list-style-type: none"> The pen height is incorrect. 	<ol style="list-style-type: none"> Make sure the pen line rubber is not worn or deformed and remains intact.

Error number	Message	Cause	Corrective action
			<ol style="list-style-type: none"> 2. Check to confirm nothing adheres to the pen line rubber. 3. After installing the pen in a commercially available pen holder, check to confirm the installed position is correct.
C63	Cutter Head	<ul style="list-style-type: none"> • The cutter vertical movement is slow. 	<ul style="list-style-type: none"> • Turn off the main power and wait a while before turning back on.  "Turning Off the Power"(P. 32)
d1b	COM VOLT[1]	<ul style="list-style-type: none"> • A problem was detected with the main PCB voltage. 	
b	PCB MAIN-F*	A fuse has blown on the main PCB.	
b5c	Main PCB V05U	A problem was detected with the main PCB 5V power supply.	
b5d	Main PCB V3R3U	A problem was detected with the main PCB 3.3V power supply.	
b5e	Main PCB V1R5D	A problem was detected with the main PCB 1.5V power supply.	
b5f	Main PCB V1R2U	A problem was detected with the main PCB 1.2V power supply.	
b60	Main PCB V24	A problem was detected with the main PCB 24V power supply.	

*1. NCU is optional.

SYSTEM HALT



- If a SYSTEM HALT number is displayed, turn off the main power and wait a while before turning back on.

Chapter 8 Appendix



This chapter

This chapter describes the machine specifications.

8.1 Specifications

Item		CJV200 series
Print head	Type	On-demand piezo head
	Specifications	One head with 400 nozzles × 8 rows each
	Resolution	Y
X		600 dpi, 1,200 dpi
Ink set	4-color	C, M, Y, K (UISS)
	8-color	C, M, Y, K, Lc, Lm, Lk, Or
Media	Type	Label paper (paper base), PVC sheet (not more than 0.25 mm in thickness, including laminating layer), fluorescent sheet, reflective sheet, window film, tarpaulin
	Maximum printing width ^{*1}	160 size: 1,610 mm 130 size: 1,360 mm 75 size: 800 mm
	Maximum width	160 size: 1,620 mm 130 size: 1,370 mm 75 size: 810 mm
	Minimum width	210 mm
	Thickness	Max. 1.0 mm
	Roll external diameter ^{*2}	Max. 180 mm
	Roll weight ^{*2, 3}	Max. 25 kg
	Paper core internal diameter ^{*4}	2 inches or 3 inches
	Printing face	Exterior/interior
	Roll end	Taped or loosely affixed to paper core
Print margins	Left/right	15 mm (default), minimum: Left/right 5 mm
	Top end	70 mm (default), minimum: Left/right 10 mm
	Bottom end	70 mm (default), minimum: Left/right 10 mm
Distance accuracy ^{*5}	Absolute accuracy	±0.3 mm or ±0.3 % of specified distance, whichever is greater
	Duplicability	±0.2 mm or ±0.1 % of specified distance, whichever is greater
Perpendicularity		±0.25 mm/1,000 mm
Media skew		Not more than 2.5 mm/10 m
Printing gap		Manual, two settings (1.5, 2.0 mm)
Clamp pressure		Auto switch (four settings) ^{*6}
Media cutting		Cutting precision (steps): Not more than 1.0 mm
Origin alignment		LED pointer
Ink supply		Ink cartridge
Waste Ink Tank		Bottle type (2,000 ml)

Item		CJV200 series	
Take-up unit		Selectable inside/outside winding	
Media heater		PRE, PRINT, POST (Independent control)	
NCU (Nozzle clogging detection)		Options	
DAS (Automatic correction function)		Provided	
Interior lighting		-	
UV unit		-	
Interface	Data transfer function	Ethernet 1000BASE-T ^{*7, 8} , USB 2.0 Hi-speed ^{*8, 9}	
Command		MRL-V	
Languages		English, Japanese, Chinese, Turkish, Portuguese, Spanish, Italian, Korean	
Noise levels	During standby	Not more than 45 dB (FAST-A, 1 m on all sides)	
	Continuous operation	Not more than 59 dB (FAST-A, 1 m on all sides)	
	Non-continuous operation	Not more than 70 dB (FAST-A, 1 m on all sides)	
Compliance with standards		VCCI Class A, FCC Class A, IEC 62368-1 ETL compliance, CE marking (EMC Directive, Low Voltage Directive, Machinery Directive, RoHS Directive), CB certified, EnergyStar, RCM marking, KC certified	
Power supply specifications ^{*10}		Single-phase 100 to 120 V AC $\pm 10\%$ /11 A, single-phase 200 to 240 V AC $\pm 10\%$ /5.5A, 50/60 Hz ± 1 Hz $\times 2$	
Power consumption	Maximum ^{*11}	Inlet 1	100 to 120 V AC: Max. 1,320 W, 200 to 240 V AC: Max. 1,320 W
		Inlet 2	100 to 120 V AC: Max. 1,320 W, 200 to 240 V AC: Max. 1,320 W
	Standard	Inlet 1	550 W
		Inlet 2	450 W
	Minimum ^{*12}	Inlet 1	4.5 W or less
		Inlet 2	-
Installation environment ^{*13}	Permissible ambient temperature	20 to 30 °C	
	Relative humidity	35 to 65 %RH (no condensation)	
	Temperature range in which accuracy is guaranteed	20 to 25 °C	
	Temperature gradient	Not more than ± 10 °C/h	
	Dust	0.15 mg/m ³ (typical office)	
	Maximum operating altitude	2000 m	
External dimensions ^{*14}	Width	160 size: 2,770 mm (2910 mm) 130 size: 2,520 mm (2660 mm) 75 size: 1,960 mm (2100 mm)	

Item		CJV200 series
	Depth	748 mm (750 mm)
	Height	1,370 mm (830 mm)
Weight ^{*14}		160 size: 140 kg (172 kg) 130 size: 130 kg (160 kg) 75 size: 105 kg (128 kg)

- *1. With setup menu margins set to the minimum (5 mm) on either side.
- *2. External diameter and weight after winding media.
- *3. Free of sagging due to weight.
- *4. 3 inch only for high-speed printing.
- *5. Excluding media size variation and initial loading fluctuations.
- *6. Partial switch supported. Including clamp off.
- *7. Printing is not possible if local guidance shows any speed other than "1000Mbps". Using a LAN Cable
- *8. The print speed may be decreased depending on the connection environment or print data. Connecting a PC to the Product
- *9. Data may be transferred to the machine too slowly, causing the carriage to pause at the left-hand or right-hand end during printing.
- *10. Excluding options.
- *11. Varies depending on print mode.
- *12. In sleep.
- *13. Ink ejection consistency may decrease in conditions outside this range.
- *14. The figures in parentheses indicate package dimensions.

Operation manual

October, 2024

MIMAKI ENGINEERING CO.,LTD.

2182-3 Shigeno-otsu, Tomi-shi, Nagano 389-0512 JAPAN

D203836-10-17102024

